

# TURNTABLE AND TOOLFRAME FROM ONE SOURCE

INDEXER ACCESSORIES | MAY 2021

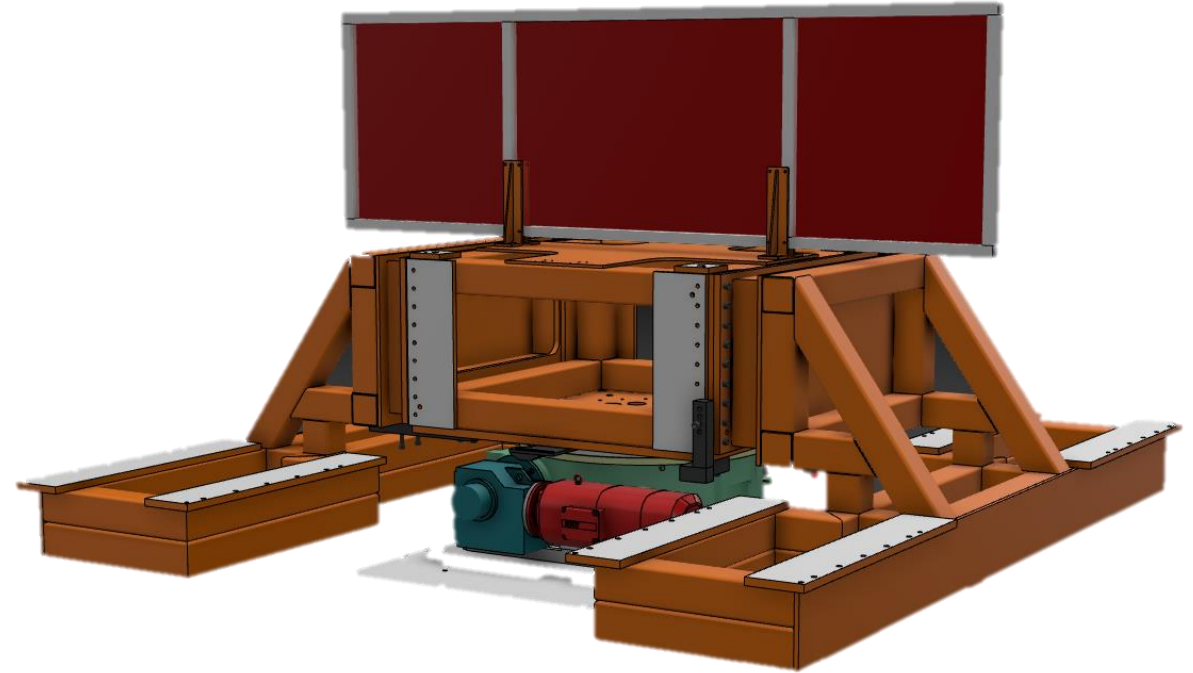

## Rotary table and tool frame from a single source.

As a manufacturer of rotary indexing tables, EXPERT-TÜNKERS stands for competence in body-in-white automation. In addition to the rotary table, we are also happy to offer you the entire framework from the foundation plate to the tool frame and the associated accessories.

Enclosed you will find some examples.

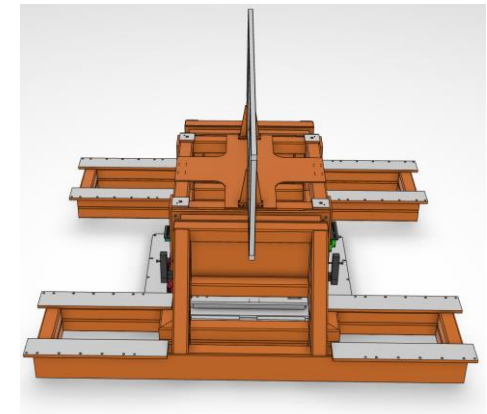
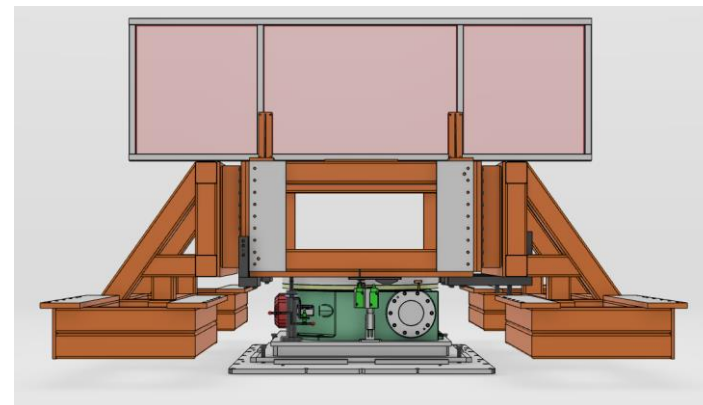
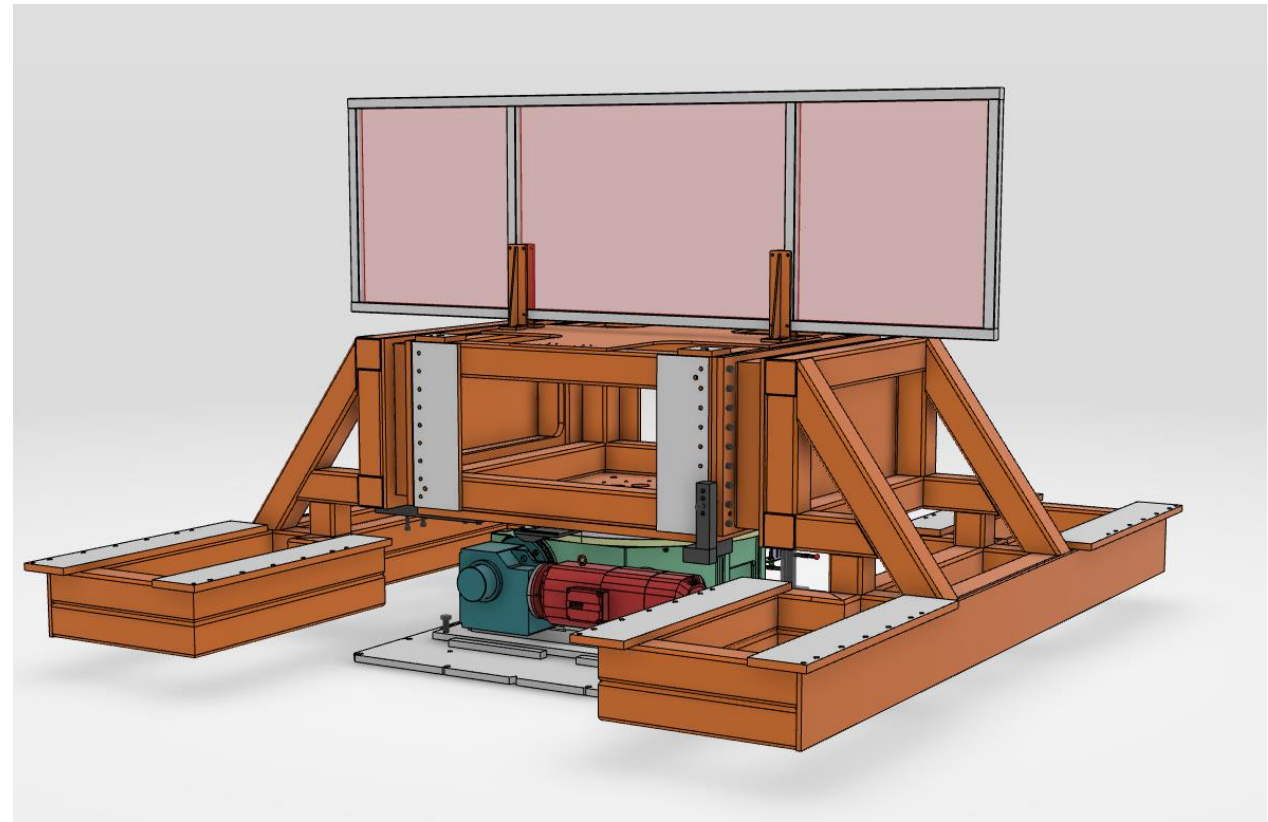

## Rotary table with flat tool carrier

- Dimensions customizable in 100 mm steps.
- Other indexes, indexing times and models available upon request.

Payload	Turntable	Max. Diameter	Number of tool surfaces	Index Time for 90°
<3700 kg	EDH810	3600 mm	2 to 4	3,0 s
3700 to 5800 kg	EDH960	4500 mm	2 to 4	3,0 s
6800 to 8200 kg	EDH1170	6200 mm	2 to 4	3,0 s

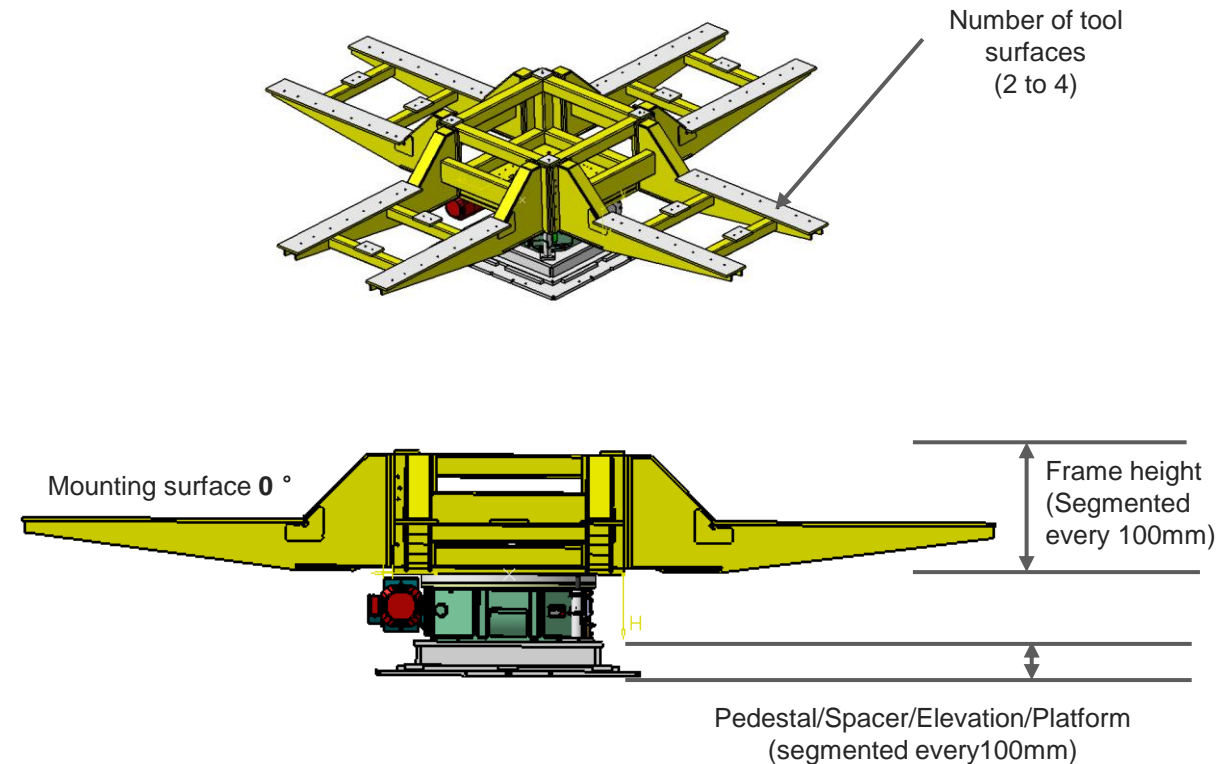
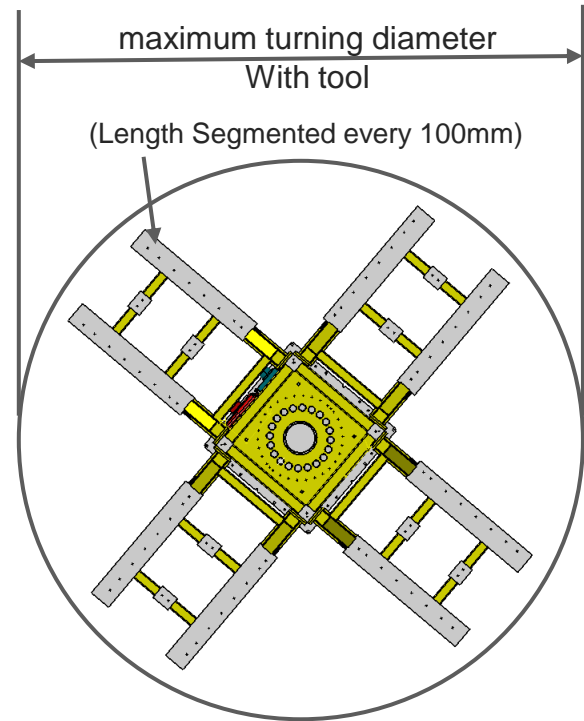

## Rotary table with angled tool frames

- Dimensions customizable in 100 mm steps.
- Angle of the carrier adjustable in 15° steps.
- Other indexes, indexing times and models available upon request.

Payload	Turntable	Max. Diameter	Number of tool surfaces	Index Time for 90°
<3700 kg	EDH810	3600 mm	2 to 4	3,0 s
3700 to 5800 kg	EDH960	4500 mm	2 to 4	3,0 s
6800 to 8200 kg	EDH1170	6200 mm	2 to 4	3,0 s

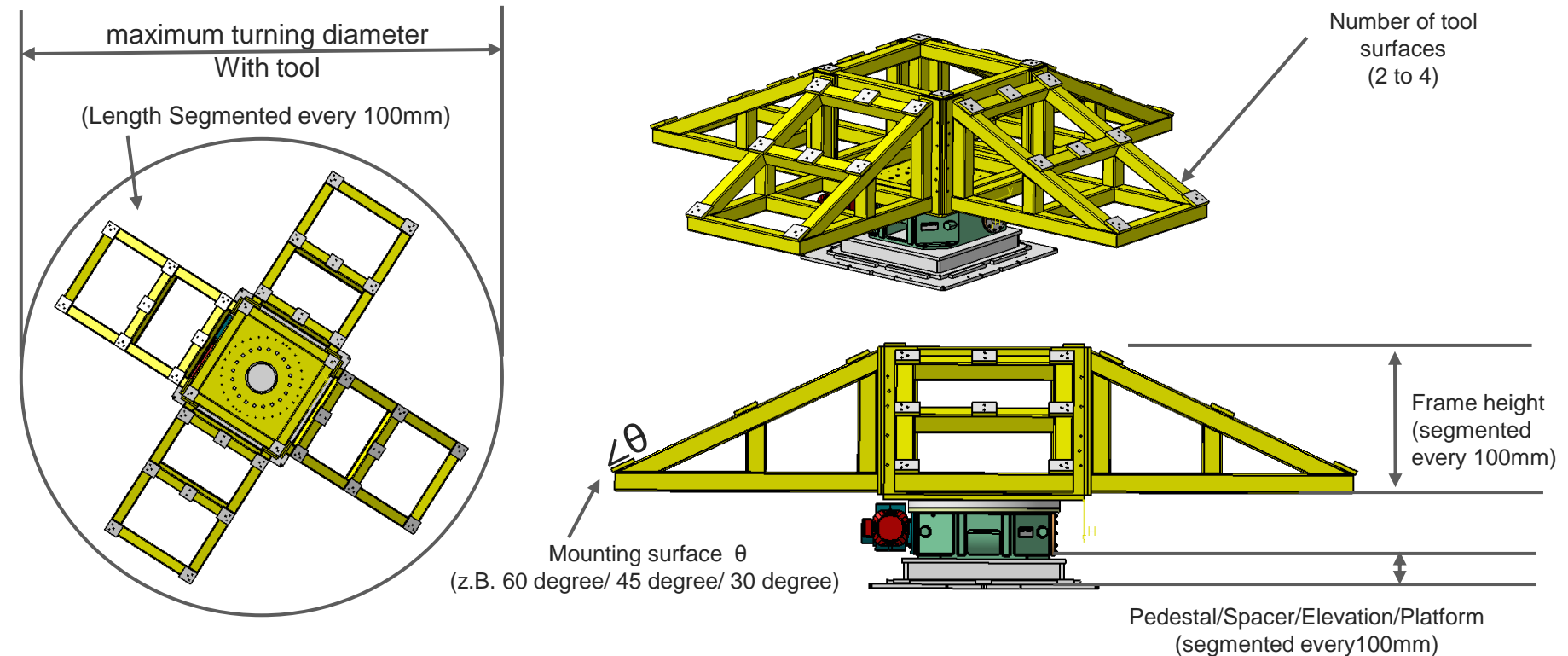

## Further supplements for your line

- Cam-switch system
- Rotary distributor / Slip ring
- Frequency inverter

We are happy to offer you the programming/optimization of the system as well as a remote service at a fixed rate.

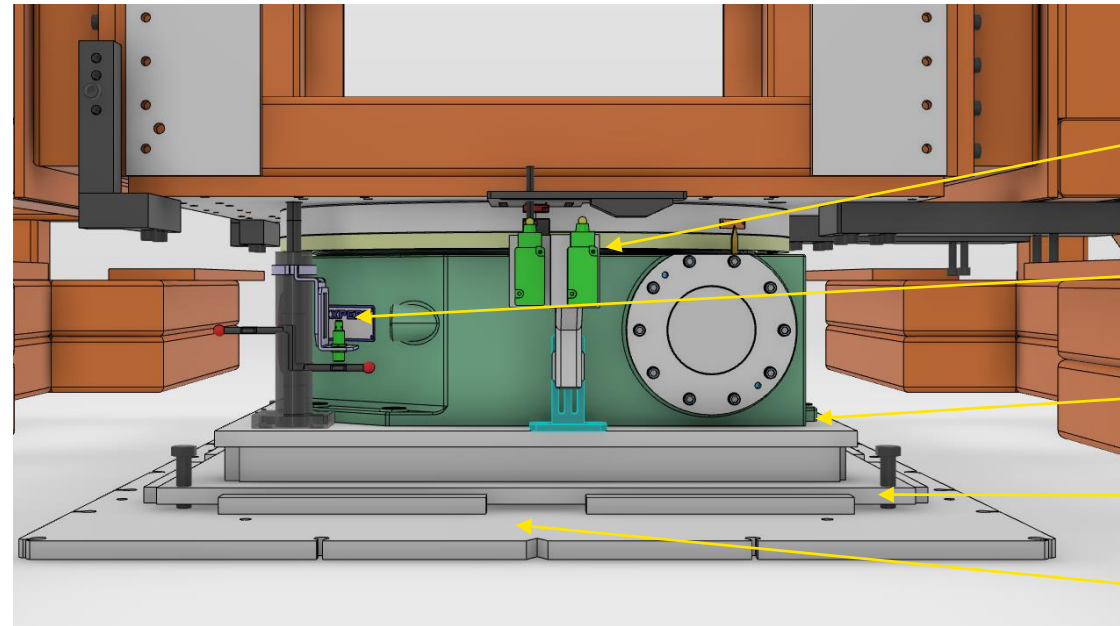

Cam-Switch System for safety / overflow

Referencing/ Locking-device Maintenance peg unit

Podest/Erhöhung

Levelling Plate and welding bars

Foundation/ Anchor Platte

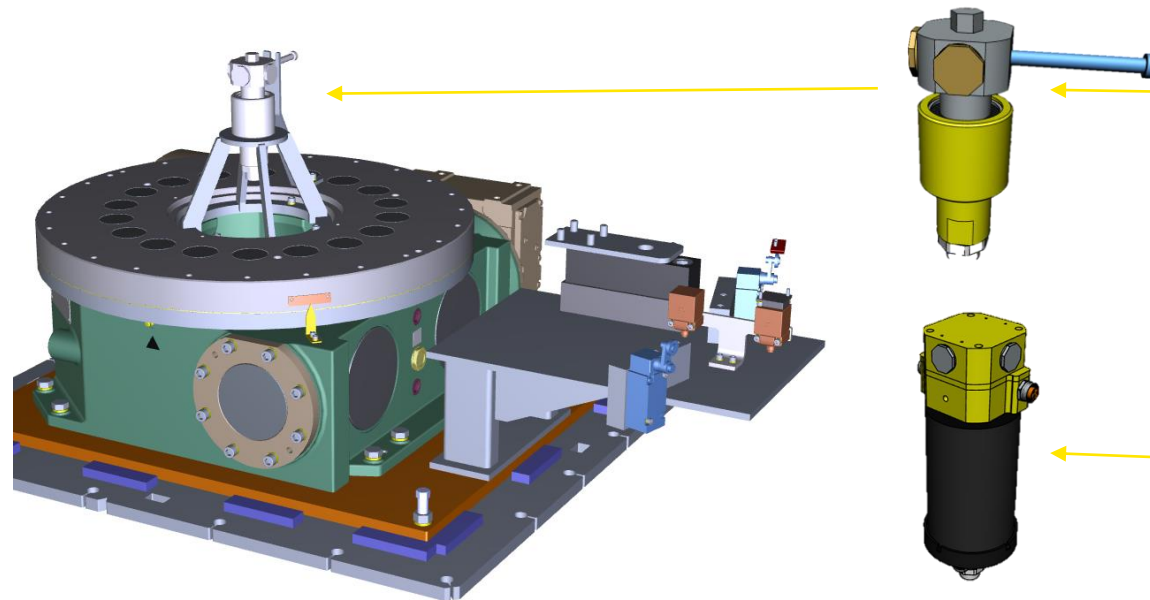

Air/ Liquid Distributor

Hybrid rotary distributor for 24V DC / 400V AC, fieldbus and further signals.

## Condition Monitoring Predictive Maintenance

So that your plant runs  
fault-free!

- With our cloud service you will be informed about due maintenance!
- The diagnosis takes place in real time. At the same time, your maintenance team is informed via the TÜNKERS CLOUD.

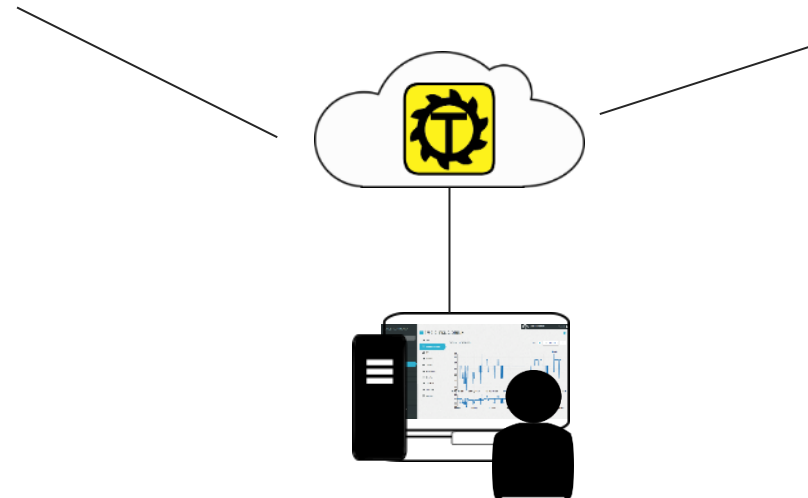
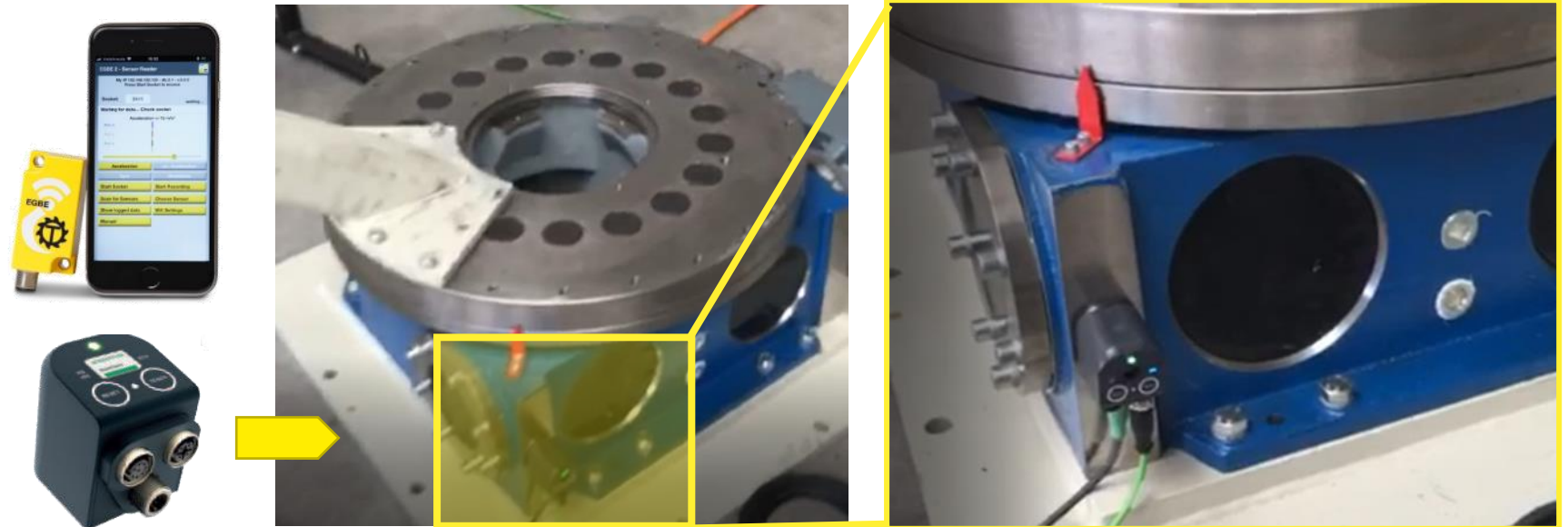

Thank you for your  
attention.

**Contact:**  
**Nuno Martins**

EXPERT-TÜNKERS GmbH  
Seehofstr. 56-58  
64653 Lorsch

Phone +49 (0) 6251 / 592-330  
Mobile: +49 (0) 172/578-0811  
Fax +49 (0) 6251 / 592-100

E-Mail [nmartins@expert-tuenkers.de](mailto:nmartins@expert-tuenkers.de)  
Internet [www.expert-tuenkers.de](http://www.expert-tuenkers.de)

