

# COMPETENCE FOR BATTERY ASSEMBLY PLANTS



# TÜNKERS

## COMPETENCE FOR BATTERY ASSEMBLY PLANTS

Within this presentation you will find solutions from the TÜNKERS Group for the use in the field of battery assembly production.

The components and systems are based on TÜNKERS Group standards, which have been partially modified for specific applications.

The first five components have already been used in battery case production and assembly. With the sixth component we would like to introduce a further solution for this special environment.

1. Transporting Technology
2. Clamping
3. Container Changing System
4. Vertical Curved Accumulating Conveyor
5. NIMAK powerGUN
6. Heavy Duty Friction Conveyor System
7. Forming Technology

# 1. Transporting Technology

Similar to the conveyor systems used in the body shop, the skids with the battery housings are conveyed through the system.

The following transport technique was used for this purpose:

- Level Lifter (EGH)
- Lift-Powered Rollerbed (HSF)
- Eccentric Lifter
- Skid Conveyor System



Level Lifter for transport of the battery cases

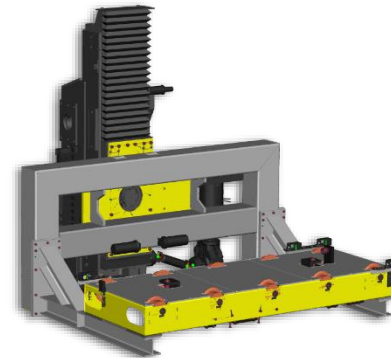

Lift-Powered Rollerbed for the battery housing production

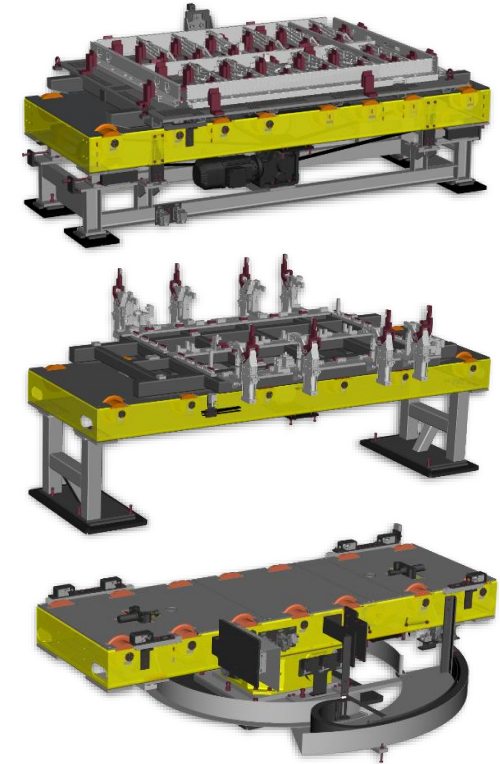

Eccentric Lifter and Skid Conveyor System for the transport of the battery housing

# 1. Transporting Technology

Level Lifter

Roller bed

Frame

Cross-Conveyor

As the ideal solution for connecting the welding level with the higher-level conveyor level, the EGH Level Lifter transports the components between the different levels.

## Technical Data:

- Vertical lift up to 20.000 mm
- Lifting speed  $v = 60 \text{ m/min}$
- Acceleration  $a = 0,5\text{m/s}^2$
- Repeatability  $\pm 1 \text{ mm}$
- Customer load up to 1.500 kg

## **Optional:**

- Maintenance platform
- Ladder
- Locking device
- Extra motor



# 1. Transporting Technology

Eccentric lifter and rollerbed

The Eccentric lifter is recommended as a simple and robust lifting element for conveying skids with the battery housings.

## Technical Data:

- Customer load up to 2.000 kg
- Vertical lift up to 200 mm
- Horizontal lift up to 6.500 mm\*
- Repeatability vertical  $\pm 0,25$  mm
- Repeatability horizontal  $\pm 1,0$  mm

\*) with servo motor

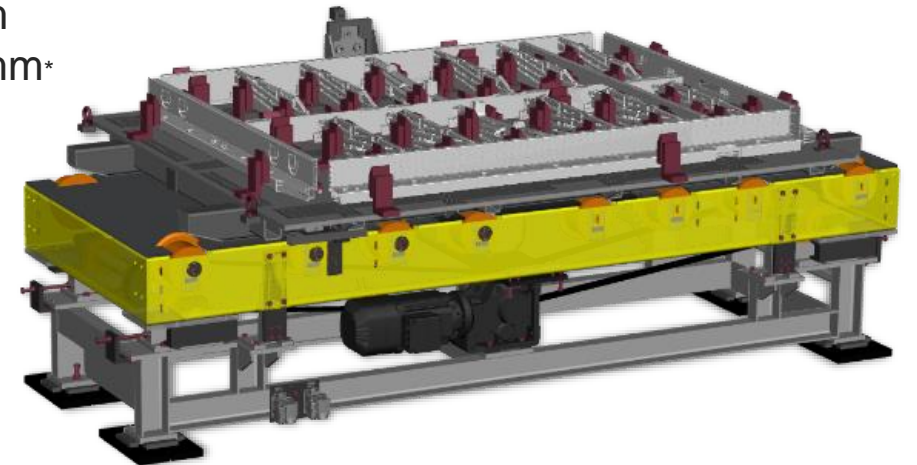

# 1. Transporting Technology

## Skid Cross-Conveyor

### Characteristics

- Compact Design
- Skid-transfer out and into the working line
- Buffer-System within the production line
- Optional reworking station output available

The Skid Cross-Conveyor systems connect different battery production lines and are also used as compact skid-storage system. Besides its core function to transfer skids in and out of the live production line, it is also possible to integrate an additional exit station for rework or control purposes.

### Technical Data:

- Customer load up to 2.500 kg
- Vertical lift up to 100 mm
- Horizontal lift up to 3.500 mm\*
- Repeatability vertical  $\pm 0,25$  mm
- Repeatability horizontal  $\pm 3,0$  mm

\*) with servo motor

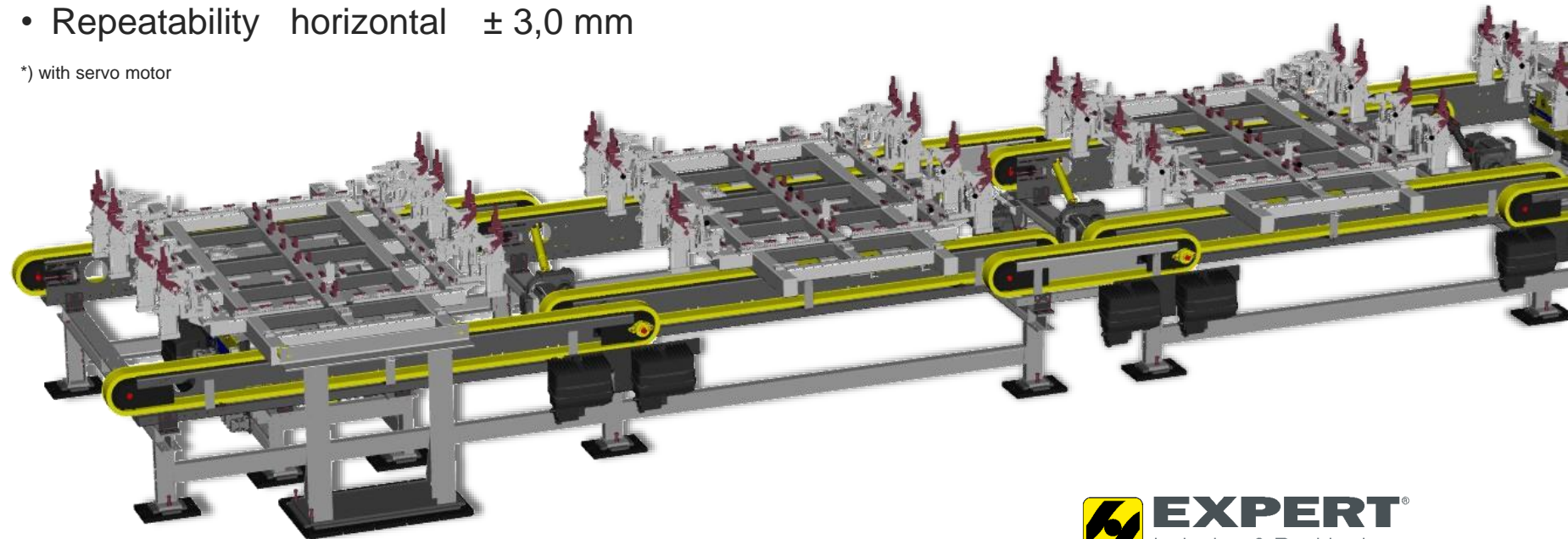

# 1. Transporting Technology

Layout example of the transport technology used for battery production

No.	Description
1	Level Lifter
2	Skid Conveyor System
3	Lift-Powered-Rollerbed
4	Rollerbeds on Rotate Unit
5	Support console
6	Fixed Rollerbed
7	Rollerbed on Eccentric Lifter

Comparable to the conveyor systems in the body-in-white, the skids with the battery housings are conveyed through the entire line. With use of the Level Lifter the battery housings are conveyed to a lower level. On the upper line of the skid conveyor system, the components are being processed.

The Lift-Powered Rollerbed at the end of the skid conveyor system allows the return of the empty skids. The turning station can be used to distribute the skids in different directions.

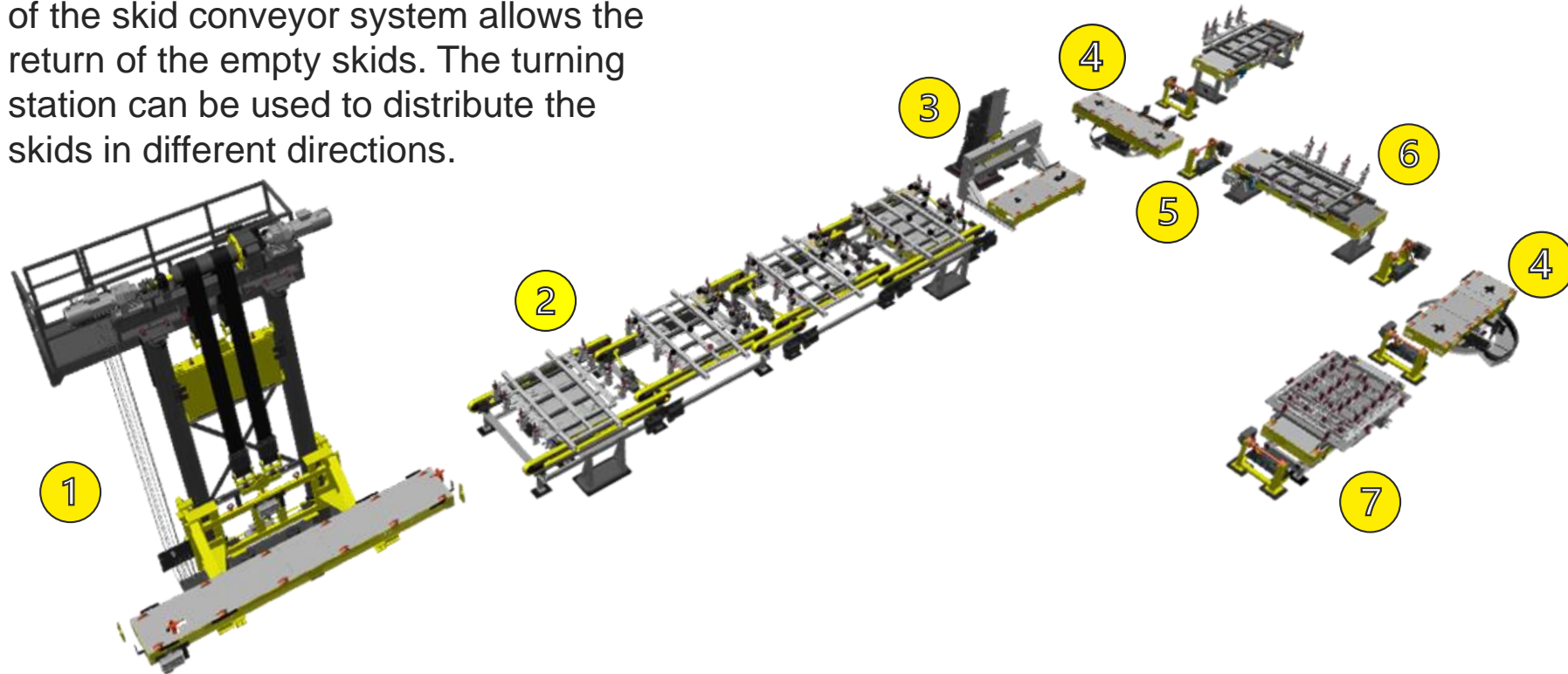

## 2. Clamping



GP 80 Parallel Gripper



GPB 12 Mini Gripper for cables



MV 63.1 - Special clamp for external actuation



Parallel-Plane Clamp (UP-Serie)



## 2. Clamping

### Parallel-Plane Clamp UP-Serie

Parallel-plane clamping with constant clamping force.

Special mechanical systems integrated in the housing with two movement steps.

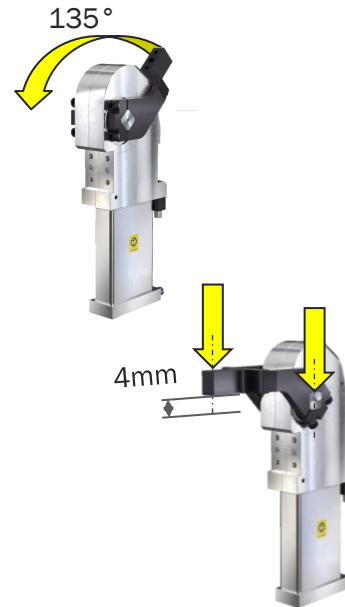

#### Stage 1: Pivoting

The clamping arm is pivoted/turned a maximum of 135° from open position to the clamping position

#### Stage 2: Clamping

Parallel-plane clamping process in which the arm is move vertically up to 4 mm to the workpiece. In the parallel-plane clamping process, constant clamping force is available regardless of the arm length.

Clamping force: 3000 N  
Weight: 5kg  
4mm force stroke

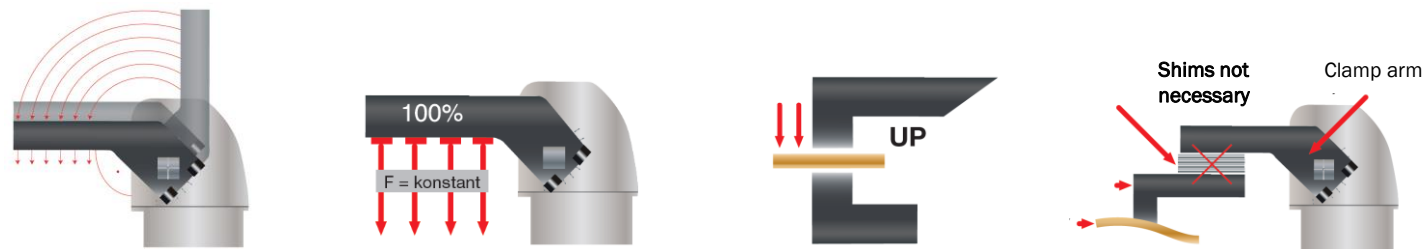

## 2. Clamping

Example of application  
Parallel-Plane Clamp  
UP-Series

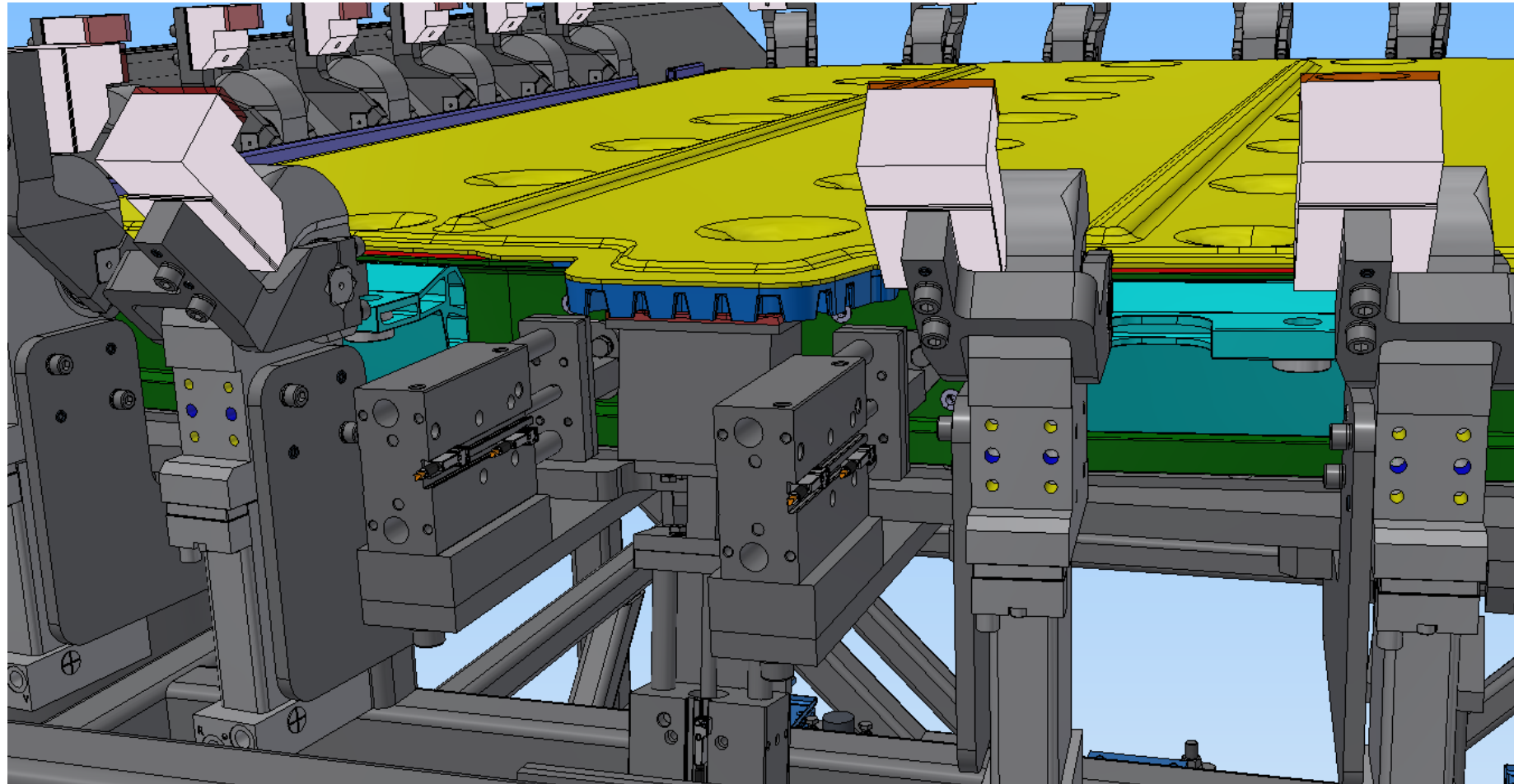

The seal of the battery tray is pressed on by our Parallel-Plane Clamp.  
Application for subsequent leak testing with compressed air.

## 2. Clamping

MV 63.1 - Special clamp  
for external actuation

The housing and the clamping arm are identical in construction to the Vario Clamp V 63.1.

The special feature can be found in the area of the drive, which is actuated externally.

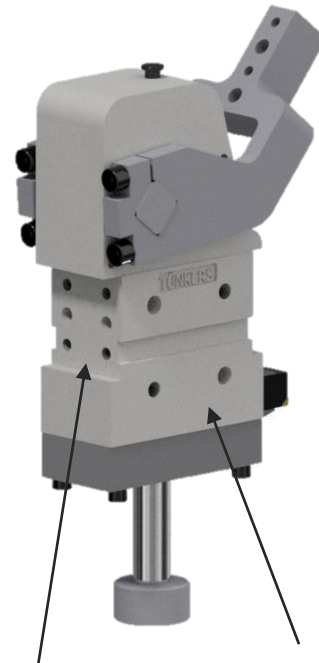

Hole pattern compatible with V 63.1

Holding torque max.: 1500Nm  
Clamping moment\*: 240Nm  
Weight: 4,7kg

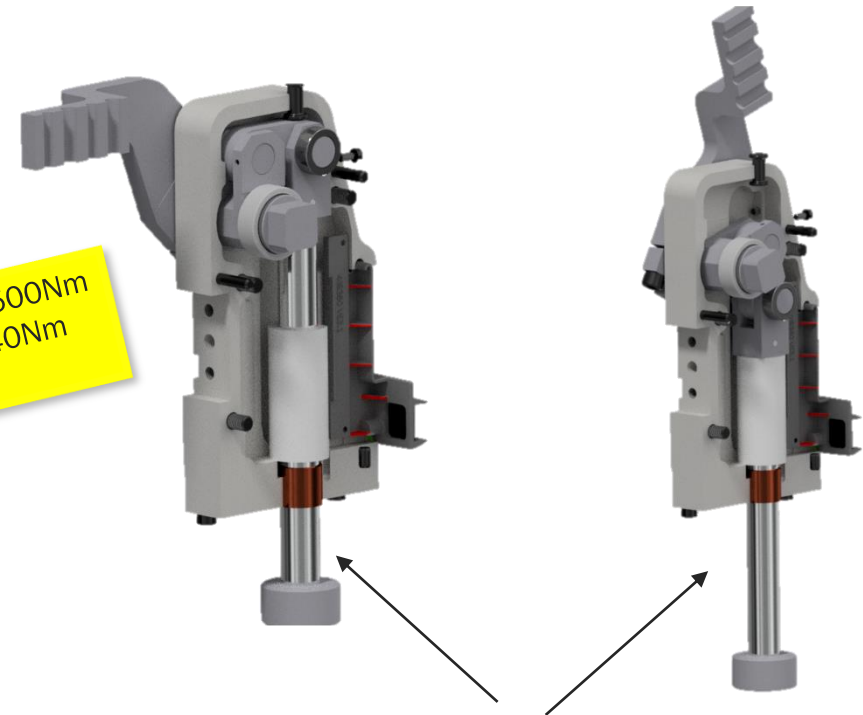

Special piston rod, for external actuation

\*at 1000N piston force

## 2. Clamping

Use of the MV - in the battery production of VW Braunschweig

The MV Clamp with its special piston rod is used on the skids of the conveyor line.

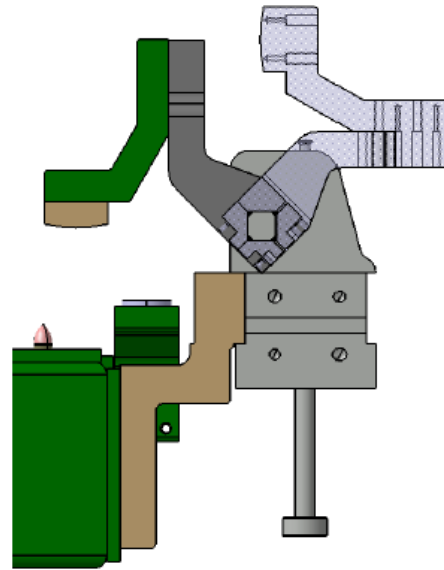

The clamp fixes the workpiece on the skid

Opening via claw

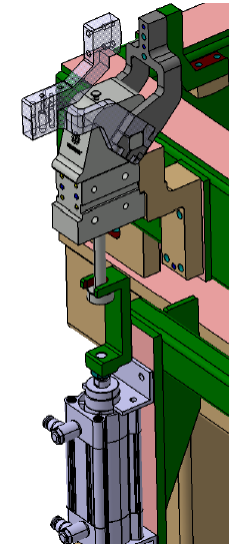

Closing with plunger

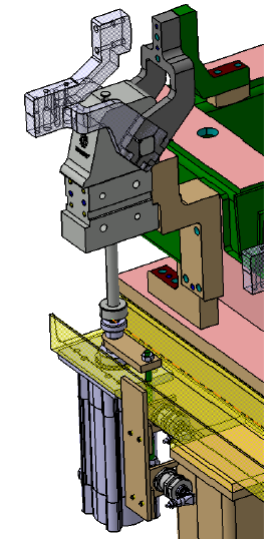

Stations are equipped with different external mechanisms which operate the clamp on its special piston rod.

## 2. Clamping

GP – Parallel Gripper

Available in Sizes:

GP 80  
GP 100  
GP 125  
GP 200

Compact gripper with wedge mechanism that drives two clamping jaws synchronously. Robust housing made of high-strength aluminum with integrated oval-shaped oblong cylinder, clamping jaw adaptor with round pivot and multiple mounting options on the housing.

### Technical Data:

- High clamping force 1800N
- Insertion of sheets
- Long clamping fingers up to 250mm



GP Clamp with long clamping finger holding a round tube profile

## 2. Clamping

GPB - Mini-Parallel  
Gripper

Available in Sizes:

GPB 12  
GPB 16  
GPB 20  
GPB 25  
GPB 32

Double-acting cylinder available in different sizes, air driven for high-precision holding of workpieces.



GPB 12 Mini Gripper - suitable for application  
such as holding cables

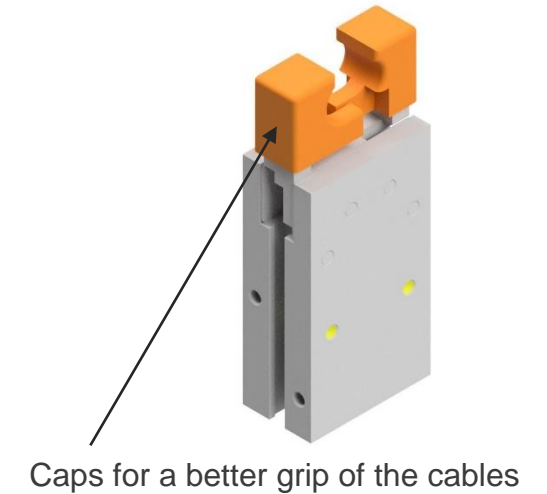
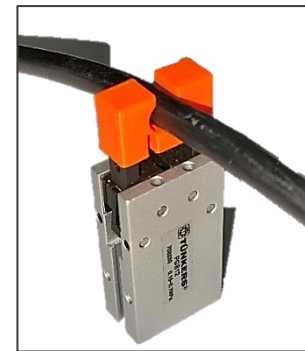

Caps for a better grip of the cables

### 3. Container Changing System

The container changing system enables the exchange of transport containers without influencing the ongoing process. The container changing system consists of a loading/unloading station. Using AGV's, containers with different components are transported into the container changing system. The containers are arranged in one sequence and are exchanged by a traverse system. Once all components have been successfully removed from the containers and the empty container is been exchanged, a plastic lid is placed on the respective container by an additional handling.

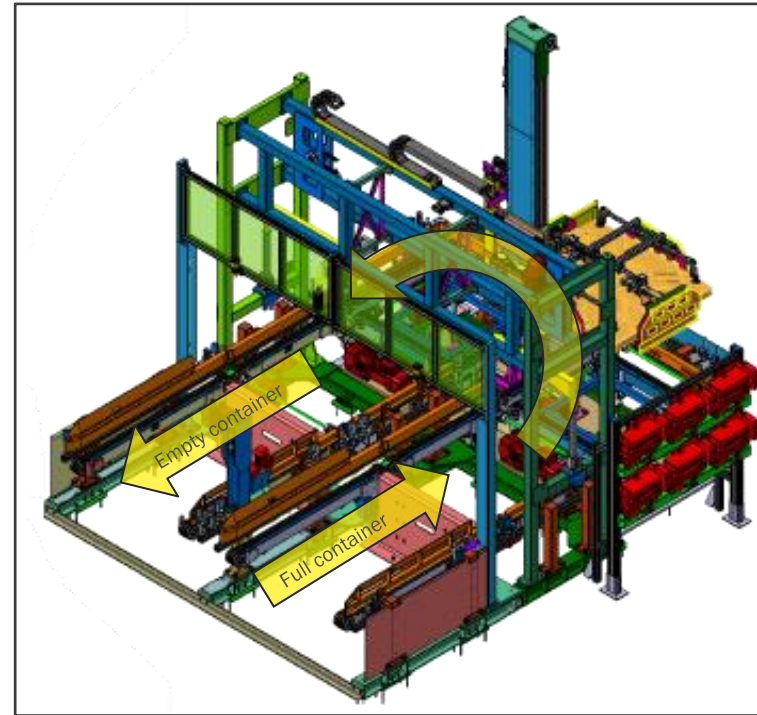

The material flow is represented by the arrows.

## 4. Vertical Curved Accumulating Conveyor

The Vertical Curved Accumulating Conveyor is based in its technology on the TÜNKERS Horizontal Accumulating Conveyor with identical basic design for profiles, pallet construction and frictions.

Due to the vertical arrangement of the accumulation conveyor, all sides of the conveyor belt that are open towards the aisle, i.e. right, left and the front side are available for loading by the worker. Moreover, loading is perfectly ergonomic from the sides.

The pallet is driven by one friction coupling only which means that a mechanical form closure is not required in the deflection area. This also eliminates the need for a protective casing.

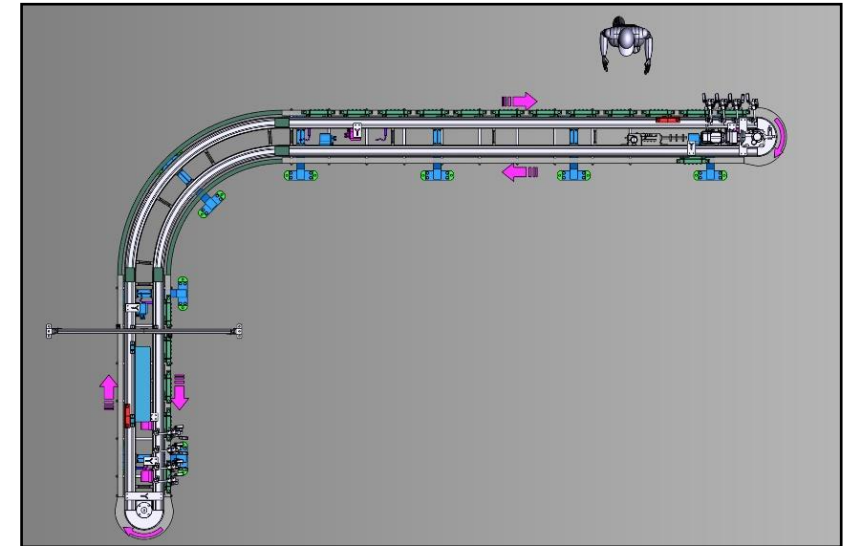
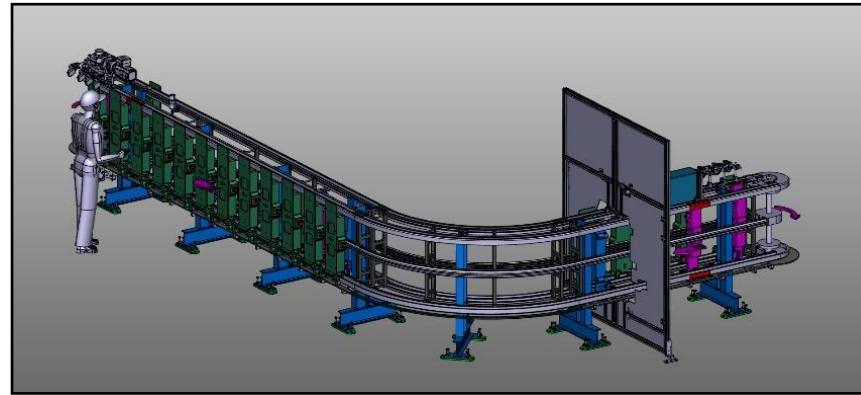



## 5. NIMAK powerGUN

This powerGUN comes with two high performance transformers parallel for high welding current and high duty welding cycle. It was optimized for use in thin or thick metal sheet range. The powerGUN is available in two version variants for different material thicknesses.

### Technical Data:

- Electrode power up to 8 kN
- Welding current up to 80 kA
- MF transformer 130, 260, 400, 500 kVA
- Duty Ratio 20%
- powerGUN I for thin sheets up to 6,5 KN/30 kA
- powerGUN II for thick sheets up to 8KN/80 kA

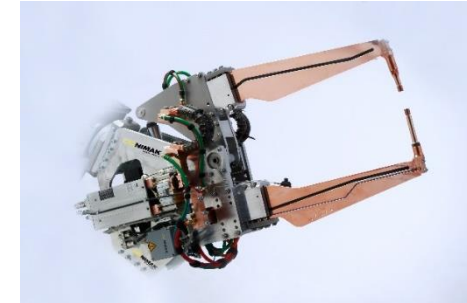

## 6. Heavy Duty Friction Conveyor Systems

LLF (0 kg to 400 kg)

LPF (400 kg to 1200 kg\*)

\*after consultation adaptable up to 1800 kg

The pallet is equipped with our patented clutch mechanism that disengages the pallet from the chain and stops the transport when the pallets are stacked. This results in a low required driving force of the motor, which makes the system very efficient.

### Technical Data:

- Dimensions adaptable to customer request
- Velocity max.  $a = 15\text{m/min}$
- Height of System max. 350mm
- Customer load up to 1.200 kg, adaptable to customer request\*
- Force before Dampening max. 400N

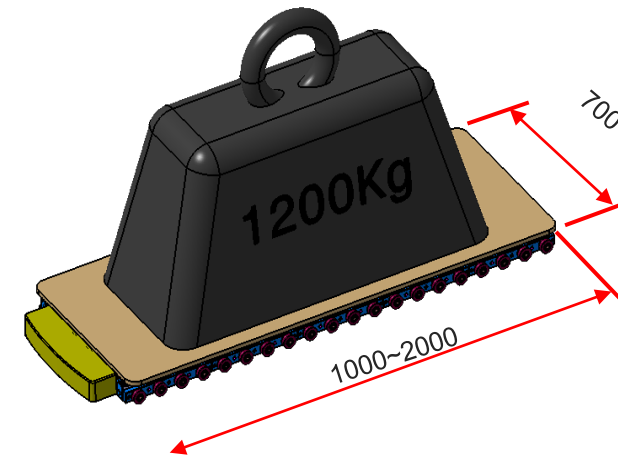
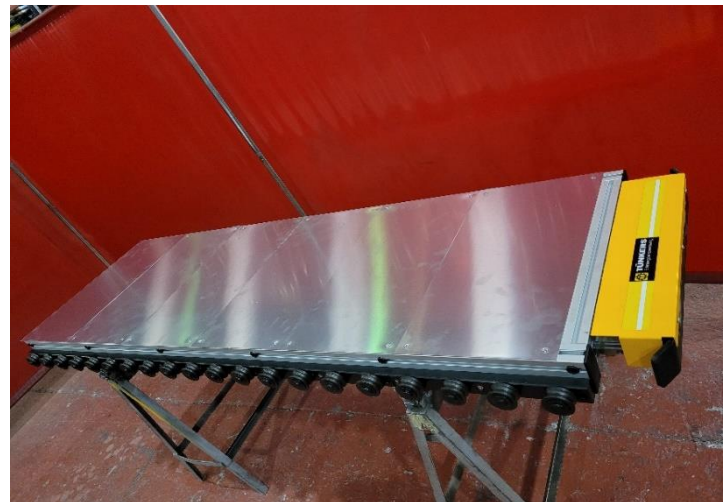

## 6. Heavy Duty Friction Conveyor Systems

Layout example for an application with four turntables and loading / unloading station:

No.	Description
1	Flexible conveyor length
2	Loading / Unloading Station
3	90° Rotation
4	Pallets

Our modular construction allows specific application configuration.

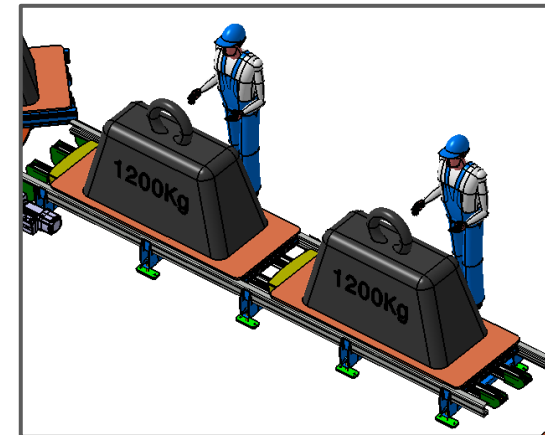
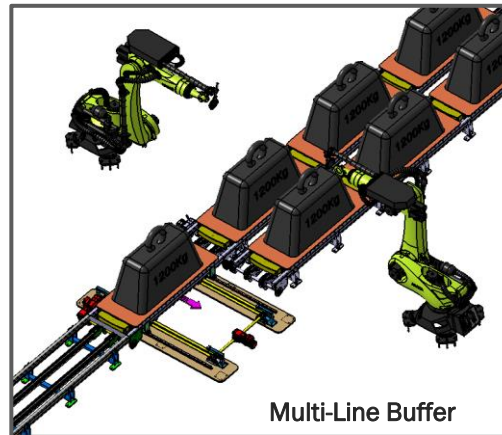
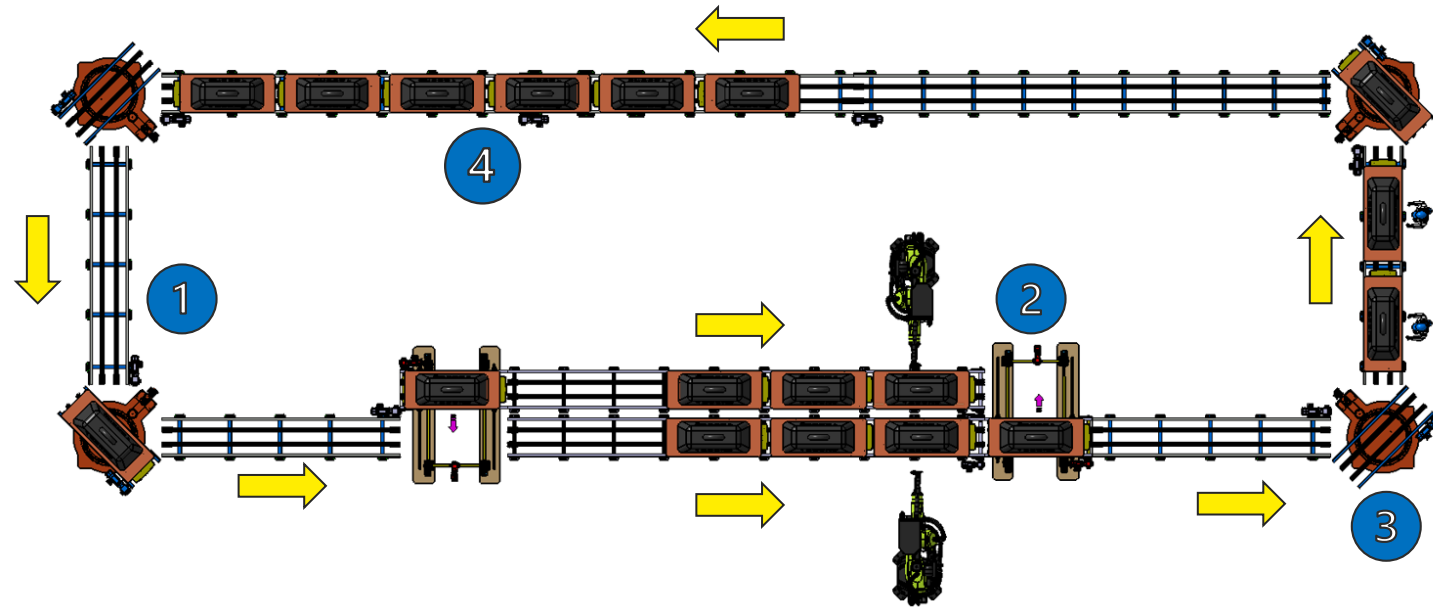

# 7. Forming

Plant for production of battery cores from so-called jelly rolls. In this process, raw parts stacked on top of each other have to be consolidated in a press.

## Example:

- 150 individual layers with a total height of 15mm
- Max. Dimensions 300x120 mm
- Heating time 60sec with approx. 8 parts pressed at the same time:
- Approx. 120 parts/h
- Loading is done on site by means of 6-axis robot and corresponding gripper system

## Hot Press

### Process data

- 20kN Pressing force
- 120 Parts/h
- Heating plate temp. max. 100°
- Pressing position controlled

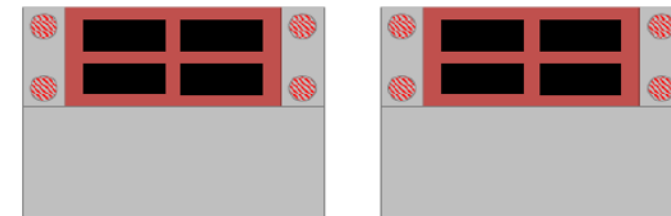
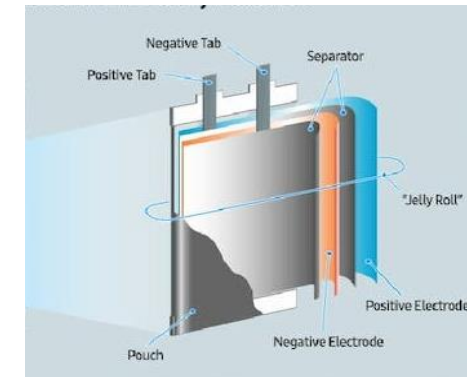
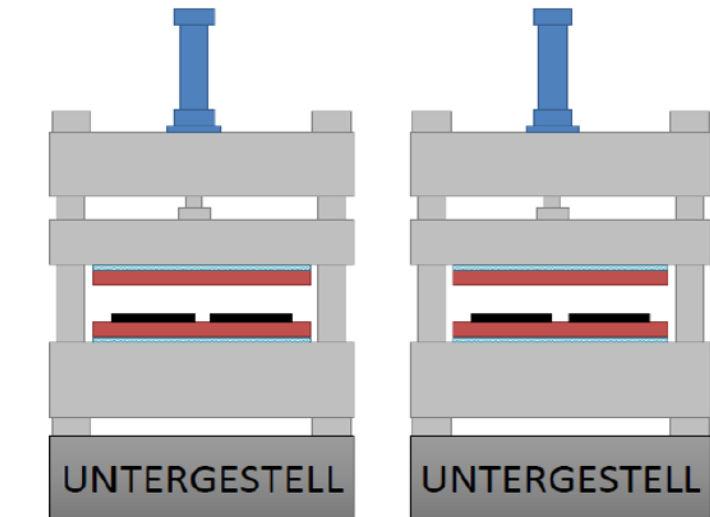

## 7. Forming

### Example for Punch Nut:

CBEZ 60-140-100 MS T02

- Stroke 140 mm, Reach 240 mm
- Electric drive (60 kN)
- Nut: M6
- Sheet thickness 1.0 mm

### **Nut Feeder**

- Weight 68 kg
- Loading weight 6 kg
- Filling volume 2dm<sup>3</sup>
- Example Nut M6

### Advantages

- Joining by material forming
- No effect of heat
- Clean system operation
- Nut size: M 5 to M 10
- Sheet thickness: 0.6 to 2.5 mm

### Requirements

- Compact dimensions
- Modular design
- Pressing force 30-70 KN
- Coaxially Punch/Die < 0.1 mm
- Low bend-up
- Integrated process monitoring optional

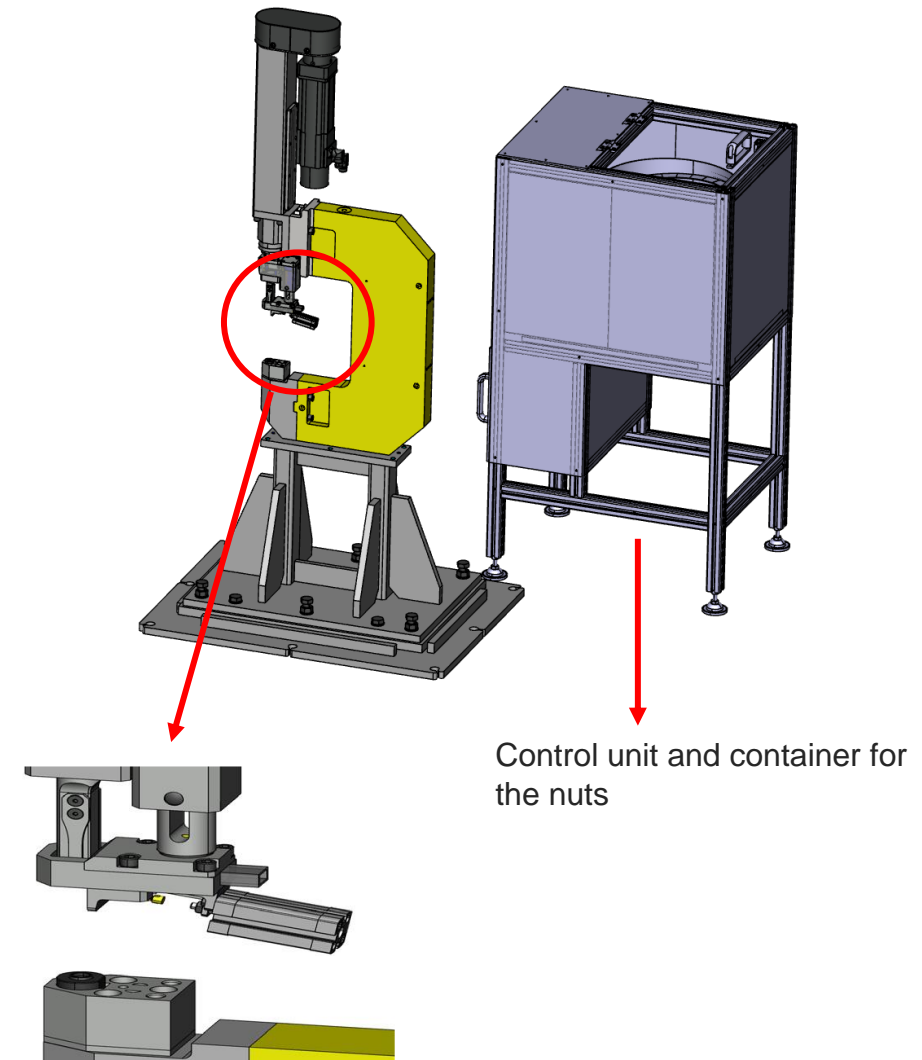

# 7. Forming

## Example for Punch Nut:

CBEZ 60-140-100 MS T02

- Stroke 140 mm, Reach 240 mm
- Electric drive (60 kN)
- Nut: M6
- Sheet thickness 1.0 mm

### Nut Feeder

- Weight 68 kg
- Loading weight 6 kg
- Filling volume 2dm<sup>3</sup>
- Example Nut M6

## Example for punching nut process

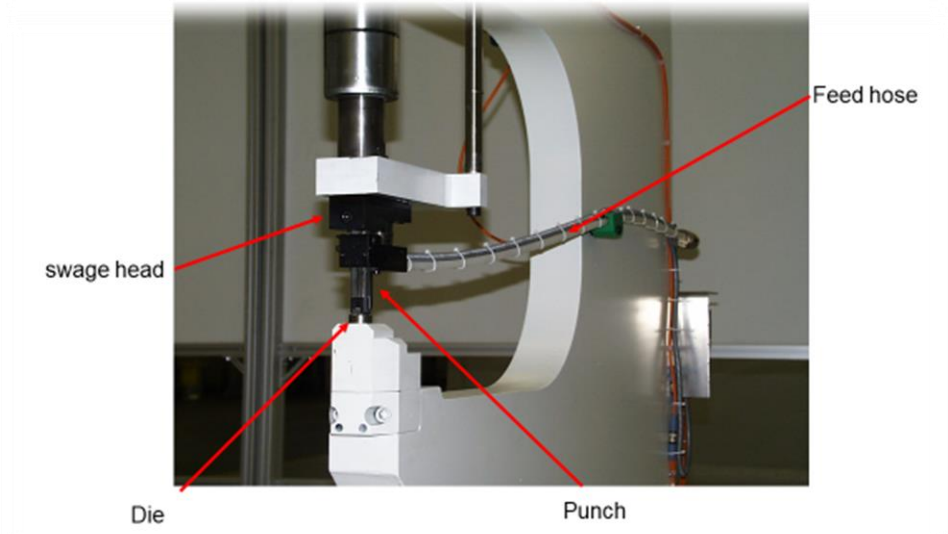
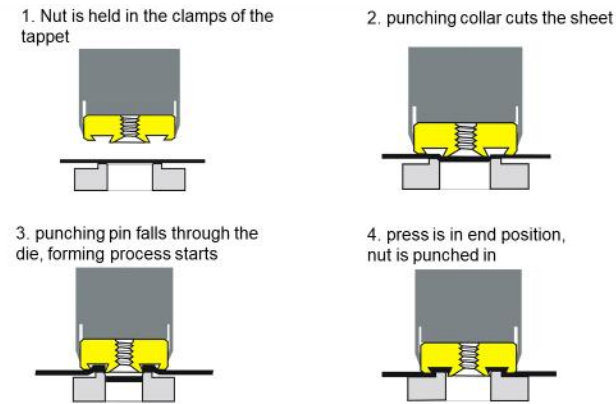

## 7. Forming

### Example for Clinching:

CBEZ 60-140-150 P T02

- Electric drive (60 kN)
- Reach 200 mm, Stroke 150 mm
- Clinch point  $\varnothing$  6,6 mm

Clinching is an alternative method to spot welding, riveting, screwing or gluing. Applicable for joining dissimilar materials, thicknesses, ductility and sizes, painted metal sheets or combinations of steel and aluminium sheets.

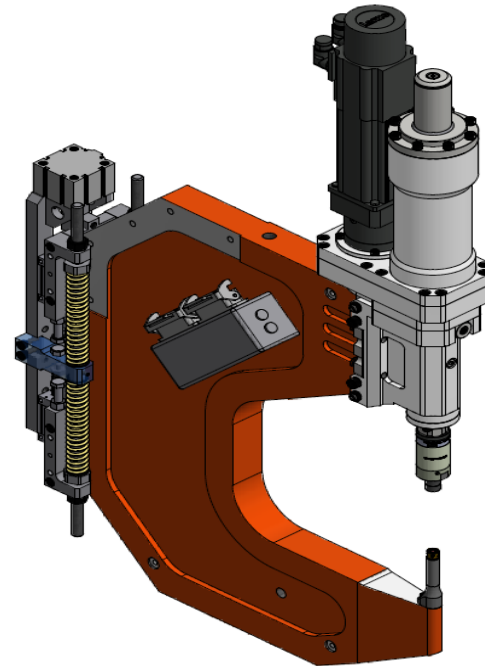

#### Process Flow

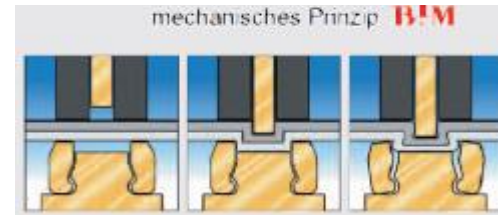

#### Tooling

BTM Standard



#### Clinching result

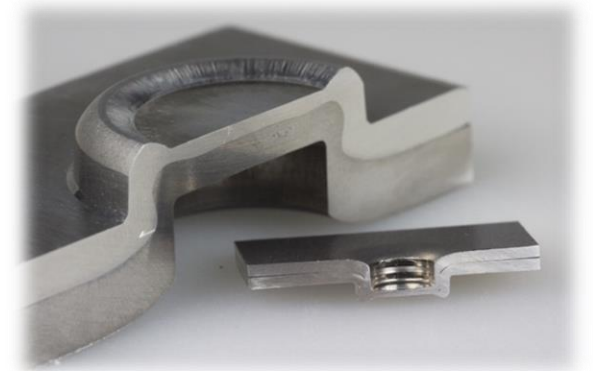

General rule:

"Hard in soft" = harder layer should be on the punch side

"Thick into thin" = the thicker sheet layer should be on the punch side

# Contacts



## Clamping

**Mr. Christian Eickhoff**

Telephone +49 (0) 2102 45 17-290

E-Mail [christian.eickhoff@tuenkers.de](mailto:christian.eickhoff@tuenkers.de)

## Forming

**Mrs. Svenja Meyer-Tokarz**

Telephone +49 (0) 2102 45 17-233

E-Mail [svenja.meyer-tokarz@tuenkers.de](mailto:svenja.meyer-tokarz@tuenkers.de)

## Conveying

**Mr. Kai Mönkediek**

Telephone +49 (0) 2102 45 17-522

E-Mail [kai.moenkediek@tuenkers.de](mailto:kai.moenkediek@tuenkers.de)



## Conveying

**Mr. Firas Kazak**

Telephone +34 934 970 743

Mobil +34 667 689 227

E-Mail [fkazak@tunkersiberica.com](mailto:fkazak@tunkersiberica.com)



## Transport Technology

**Mr. Nuno Martins**

Telephone +49 (0) 6251 592-330

E-Mail [nmartins@expert-tuenkers.de](mailto:nmartins@expert-tuenkers.de)



## Welding

**Mr. Kay Nagel**

Telephone +49 (0) 2742 7079 -111

E-Mail [kay.nagel@nimak.de](mailto:kay.nagel@nimak.de)





# THANK You



 **TÜNKERS**<sup>®</sup>  
Erfindergeist serienmäßig.

