

EXPERT-TÜNKERS

Trunnion Systems ETS

- For more than 50 years, EXPERT has been supplying rotary indexing tables for trunnion drives.
- More than 200 systems were already designed and manufactured, making EXPERT-TÜNKERS the leading supplier of complete trunnion systems.
- The largest systems ever built were hexagonal trunnions, turning 180° in 6 sec. and moving a total mass of 35 t.
- Based on their experiences, the **trunnion system ETS** has been designed in cooperation with well-known OEM's.

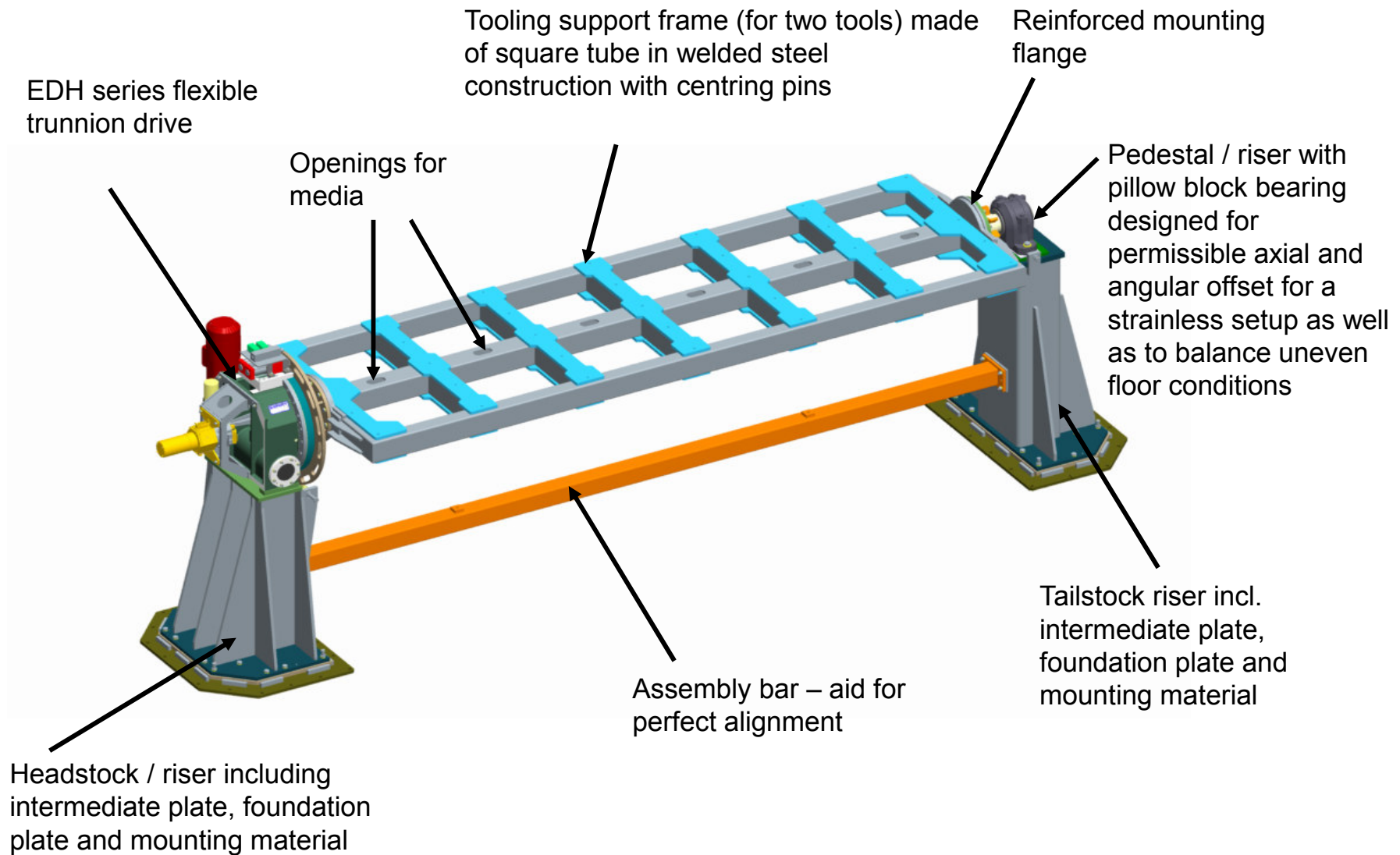



Precise positioning due to low-backlash, torsion-proof transmission elements, low roll pitch and pre-loaded table plate. No additional positioning pin required, no cycle time loss

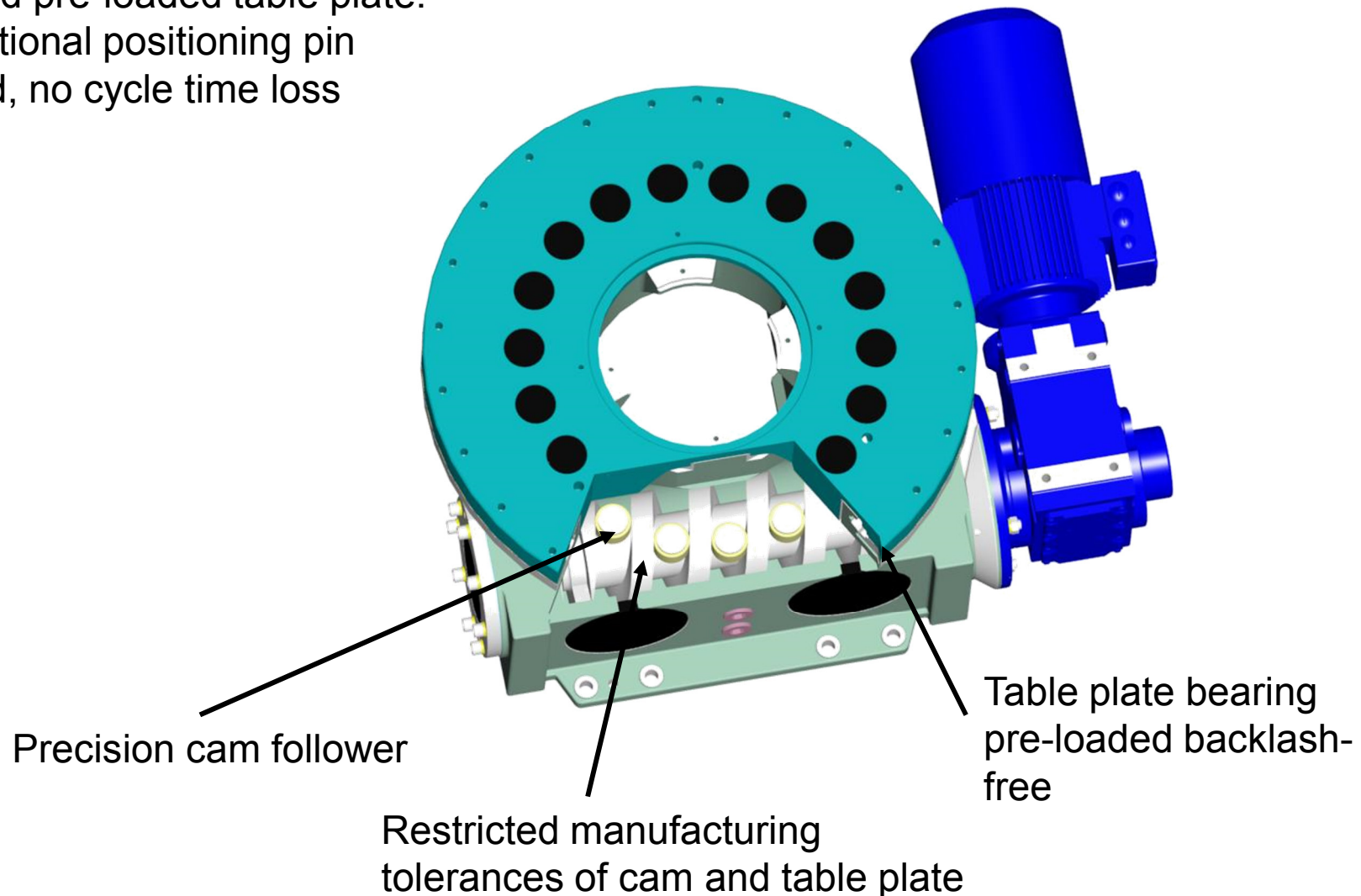

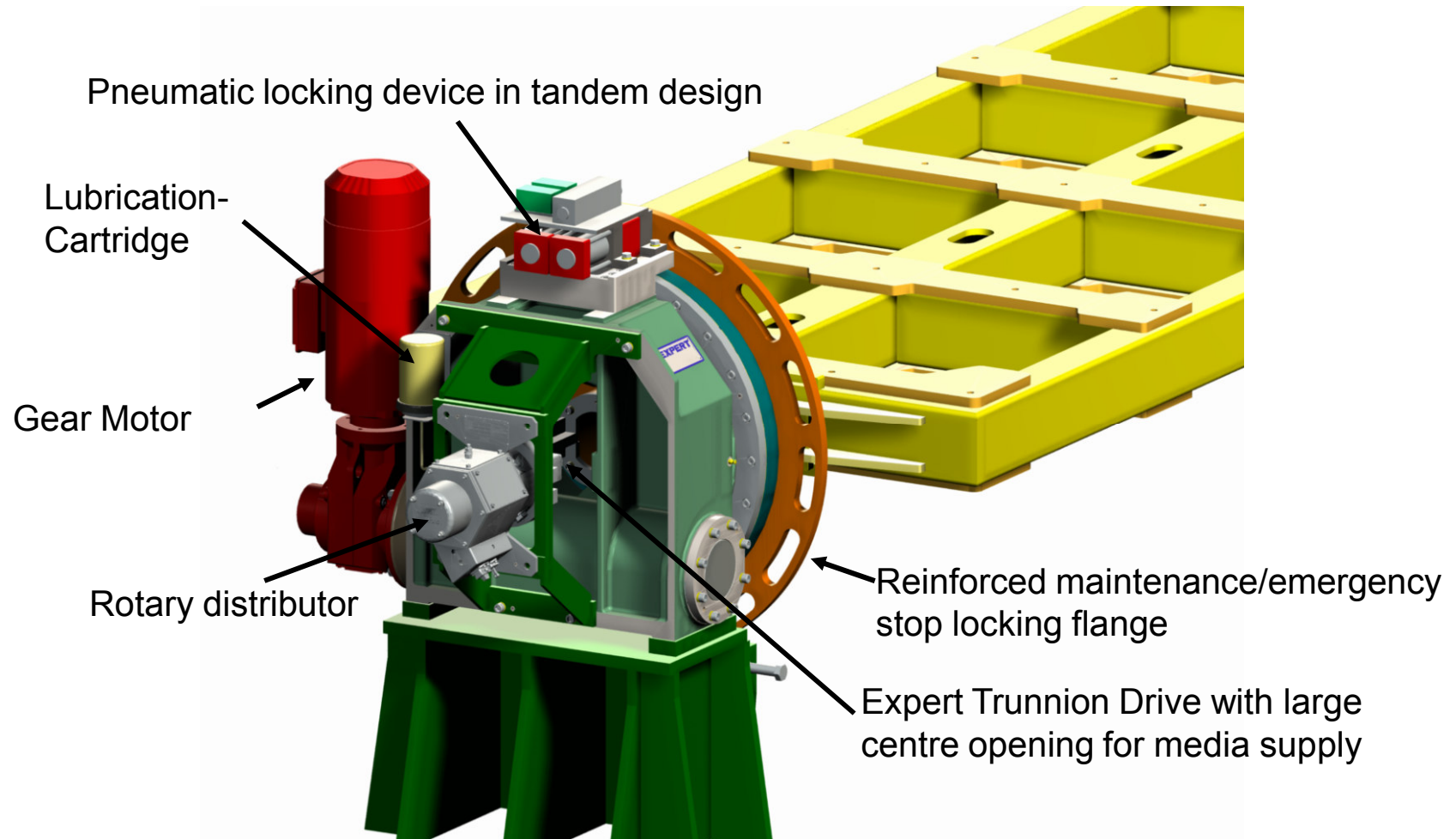

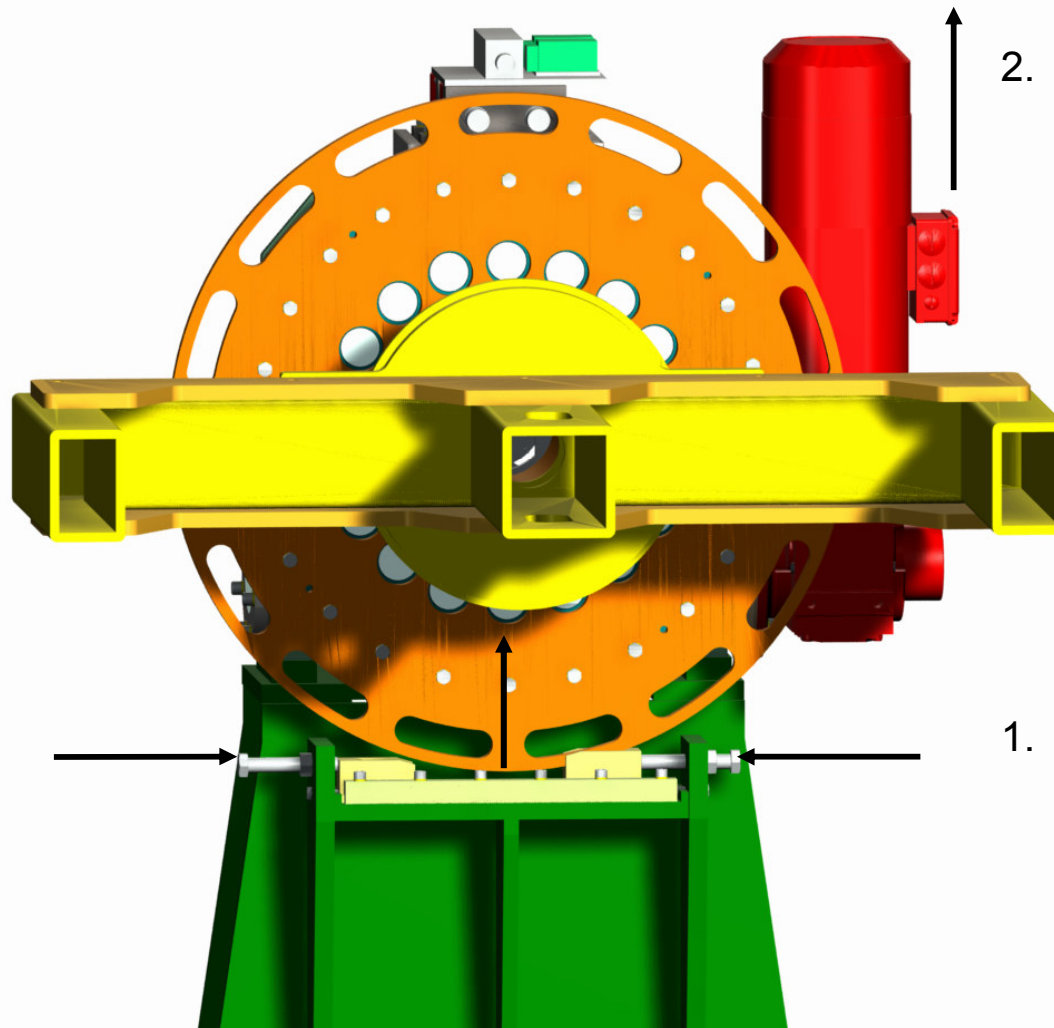

2. The rotary table is released from the locking rim and the machine base and can be replaced as a complete unit

1. By means of the lateral screws the trunnion and the locking rim can be supported via the lifting wedges

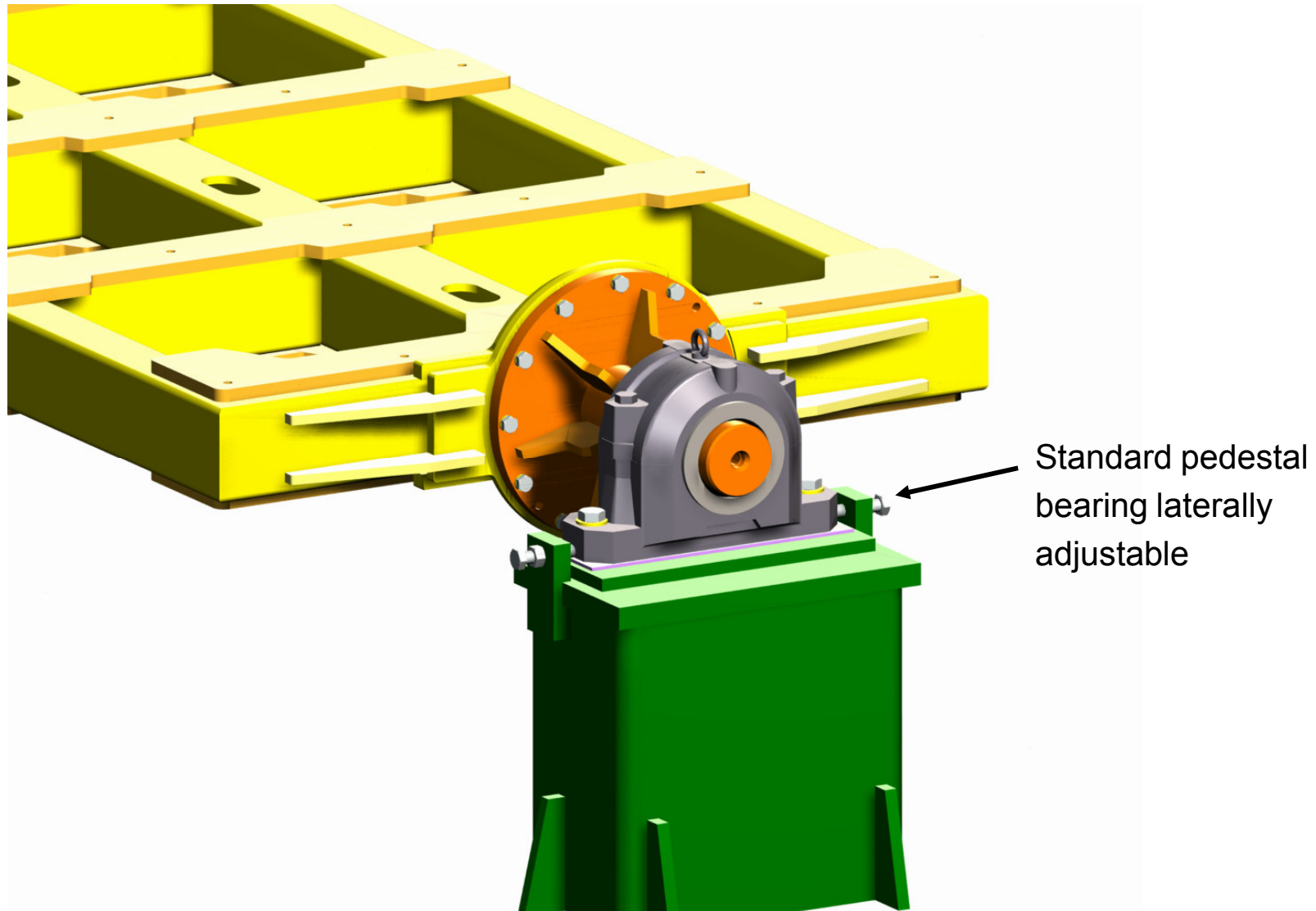

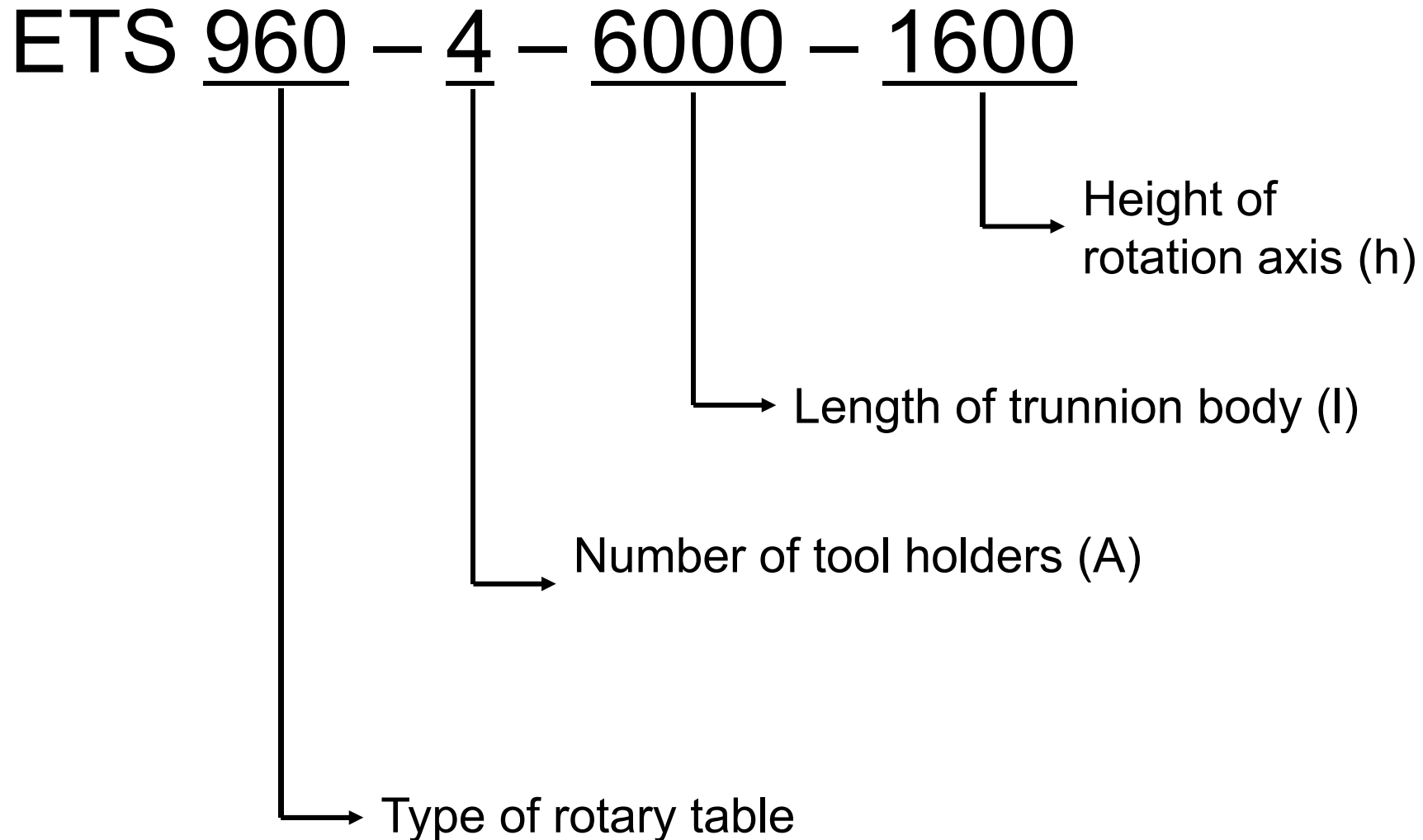

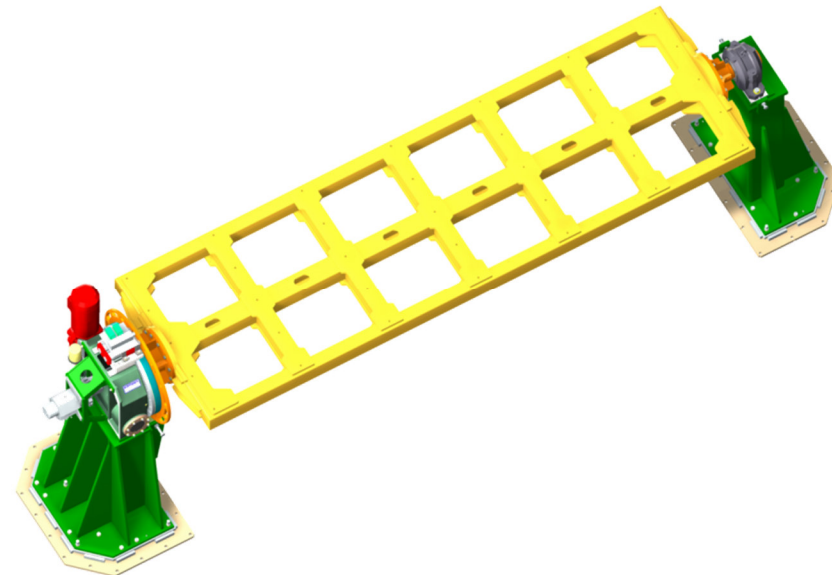
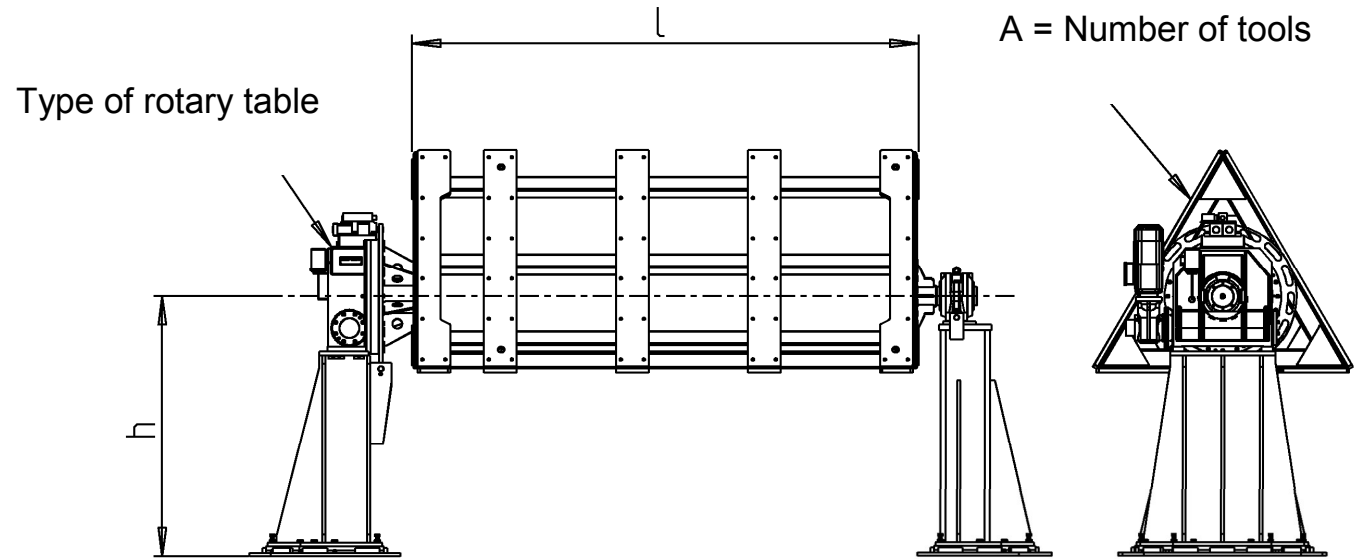

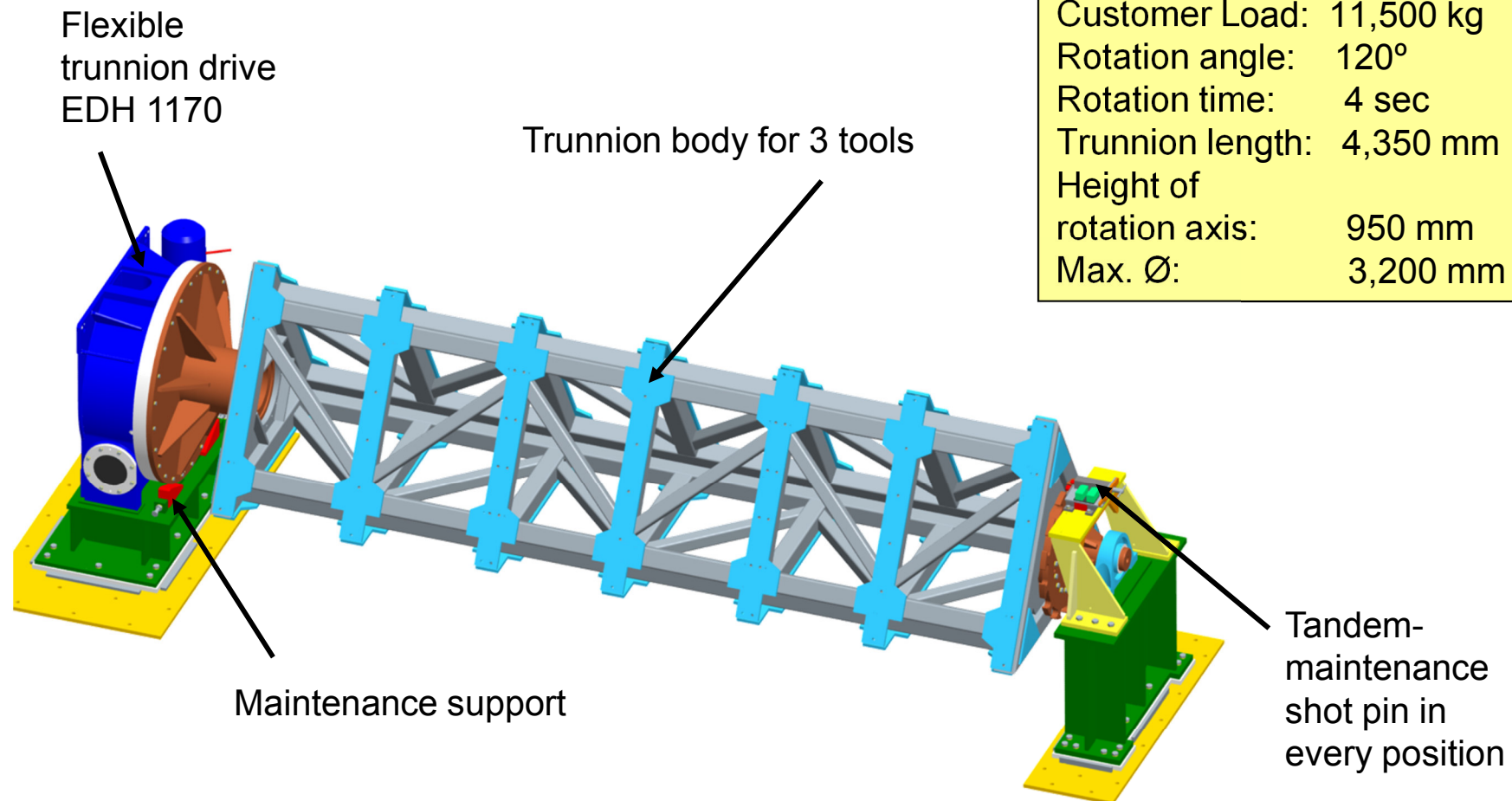

Flexible trunnion drive
EDH 1170

Trunnion body for 2 tools

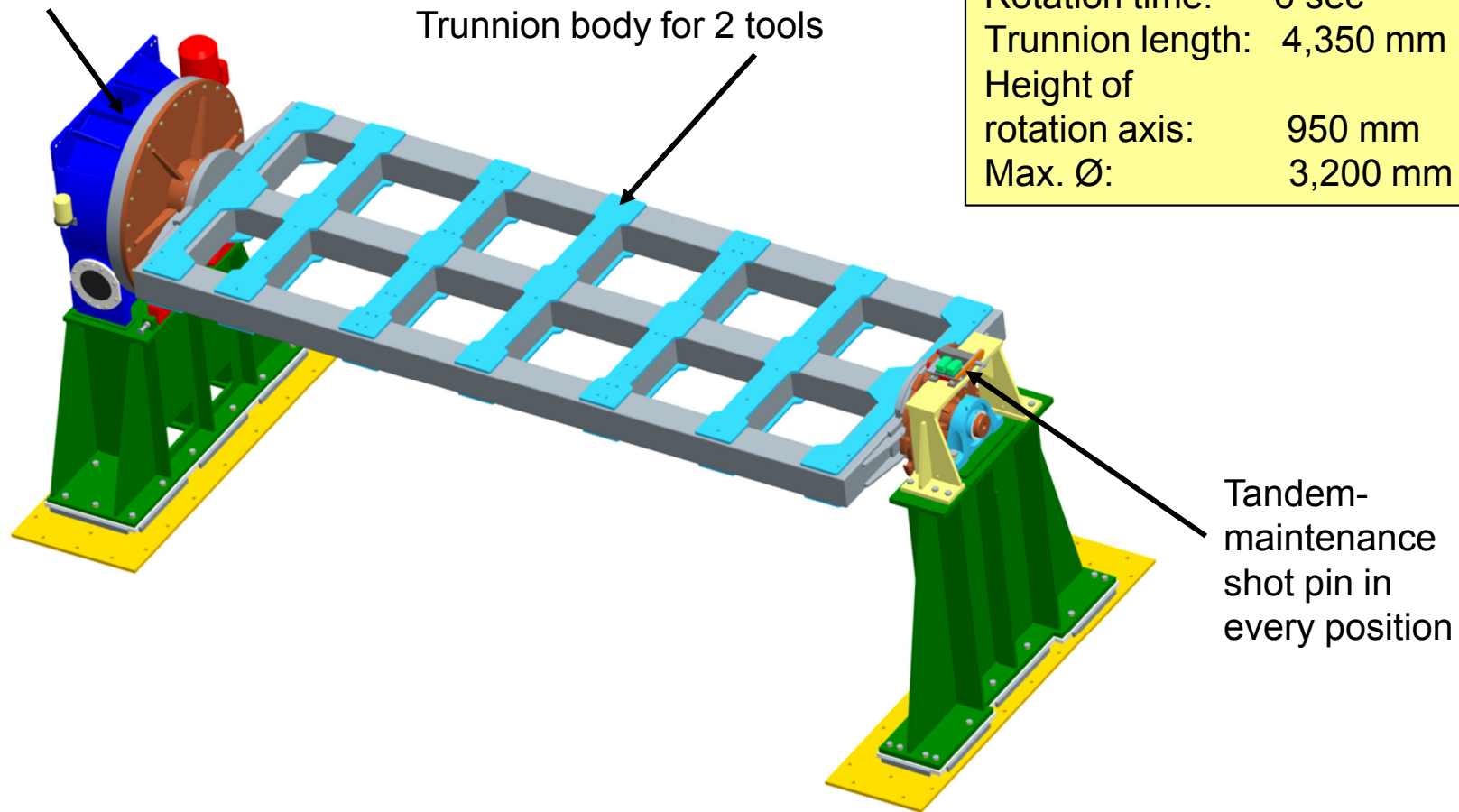

Technical data:

Trunnion drive:	EDH 1170
Customer Load:	9,000 kg
Rotation angle:	180°
Rotation time:	6 sec
Trunnion length:	4,350 mm
Height of rotation axis:	950 mm
Max. Ø:	3,200 mm

Tandem-
maintenance
shot pin in
every position

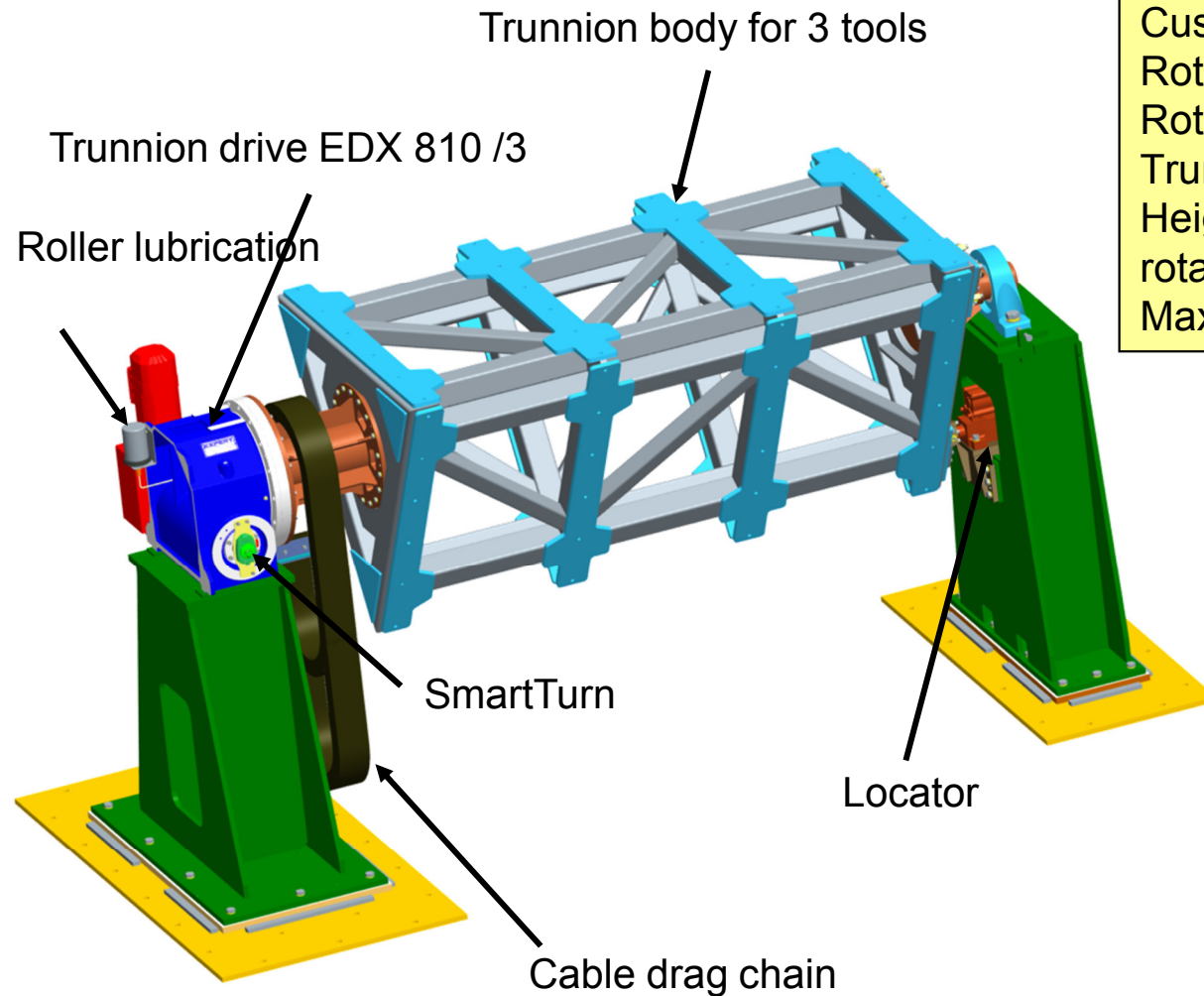

Technical data:	
Trunnion drive:	EDX 810/3
Customer load:	3,800 kg
Rotating angle:	120°
Rotation time:	6,4 sec
Trunnion length:	2,200 mm
Height of rotation axis:	1,490 mm
Max. Ø:	2,200 mm

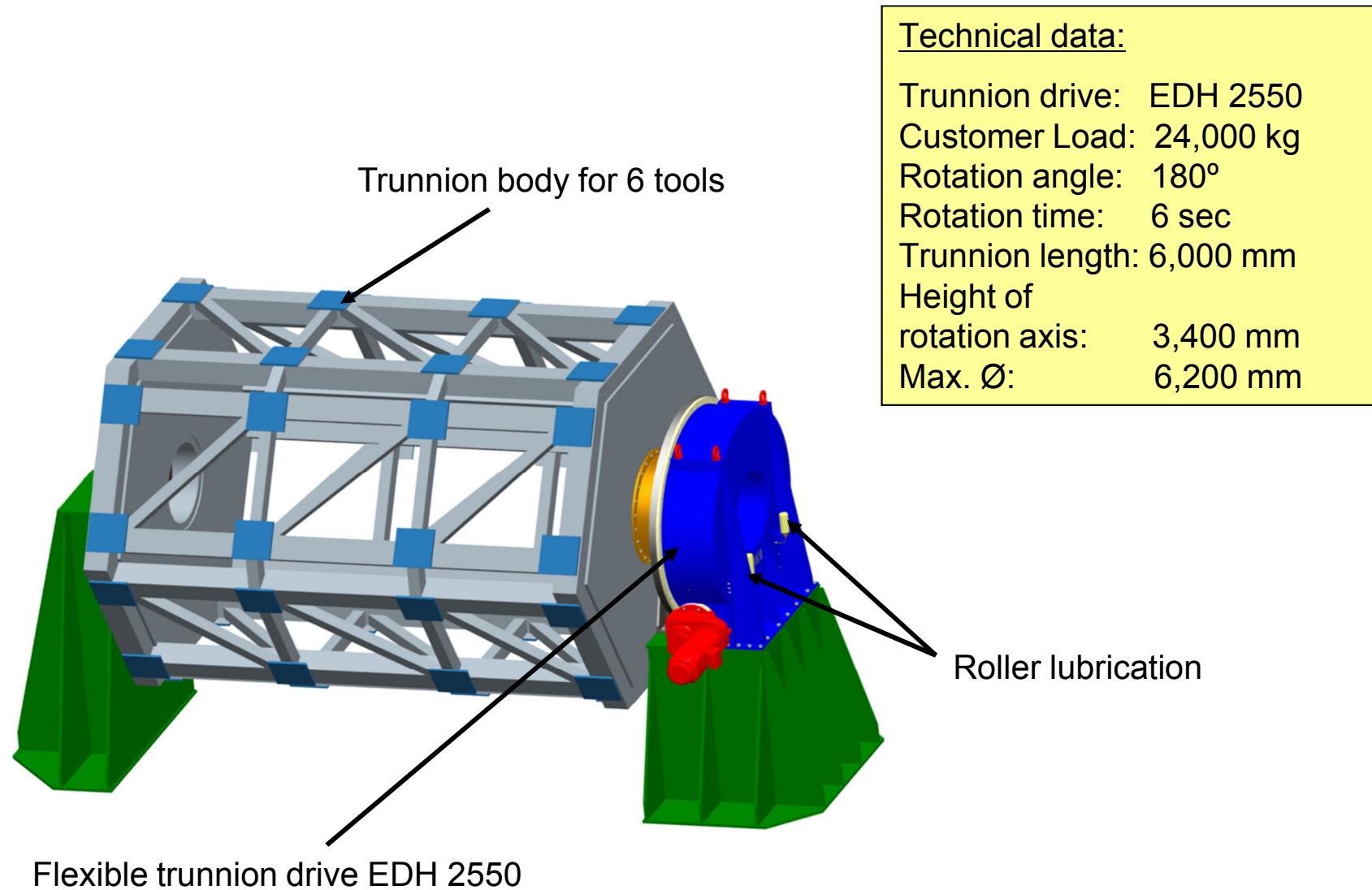

Thank you for your attention.

Contact:

EXPERT-TÜNKERS GmbH
Seehofstr. 56-58
64653 Lorsch

Phone +49 (0) 6251 / 592-0
Fax +49 (0) 6251 / 592-100

E-Mail sales@expert-tuenkers.de
Internet www.expert-tuenkers.com