

EXPERT-TÜNKERS

Catalogue







Transporting Technology

TRANSPORTING TECHNOLOGY | SEP 2023



Lift Powered Roller beds

Roller bed lifter with horizontal and vertical transportation

-  Up to 2.000 kg customer load
-  Up to 2.000 mm stroke
-  Up to 8.000 mm stroke
-  Compact design
-  Flexible assembly of the Lifter
-  +/- 0,02 mm vertical Repeatability
-  +/- 2 mm horizontal Repeatability
-  Soft part pick-up with $v = 0$ m/s

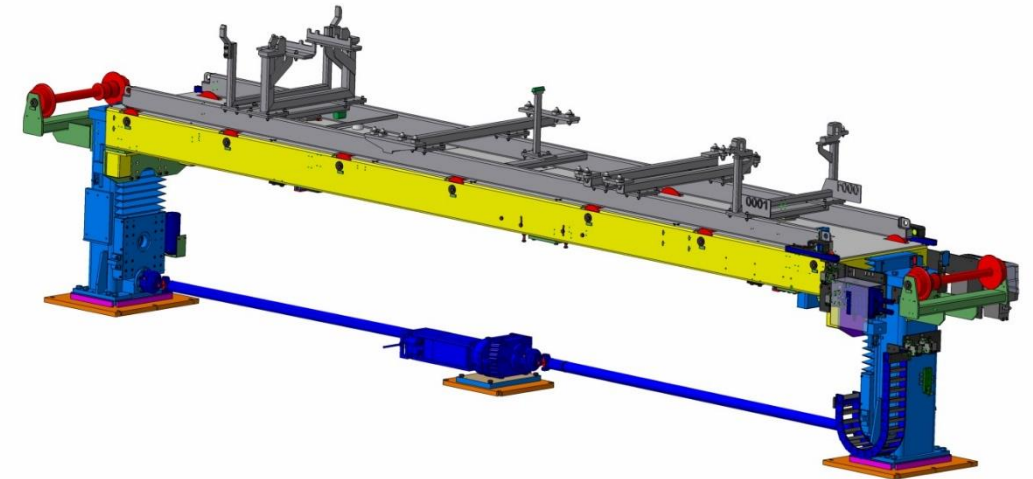



Geometrical skids- Eccentric Lifter

**Robust eccentric lifter with short vertical motion,
for roller beds with heavy and geometrical skids**

 Up to 2.000 kg customer load

 Up to 200 mm stroke

 Up to 6.500 mm stroke

 Compact design

 +/- 0,2 mm vertical Repeatability

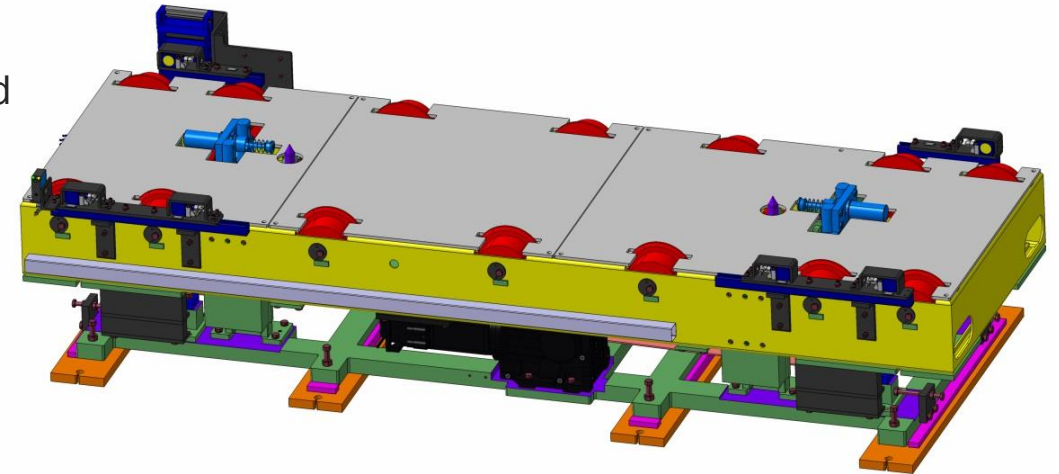

Eccentric Lifter

Robust eccentric lifter with short vertical motion, for roller beds



Up to 2.000 kg customer load



Up to 300 mm stroke



Up to 8.000 mm stroke



Compact design





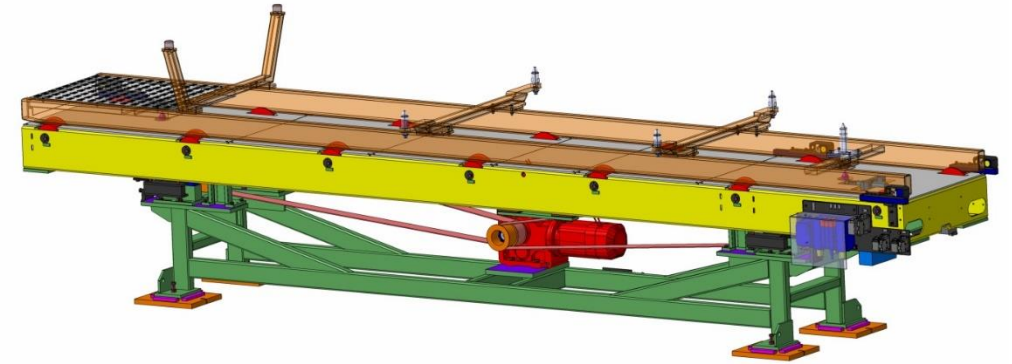



+/- 0,2 mm vertical Repeatability



Dual-gear-Lifter with Spring compensation

Dual-gear-Lifter with a Roller bed and with spring compensation system

-  Up to 1.000 kg customer load
-  Up to 1.000 mm stroke customizable
-  Up to 8.000 mm stroke
-  600 mm minimal Height
-  **-30%** Energy demand
-  Soft part pick-up with $v = 0$ m/s

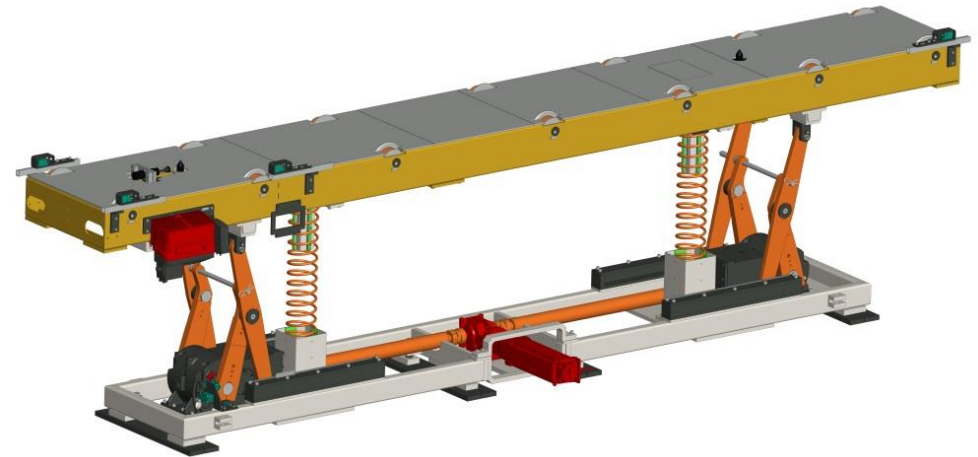

Robust Belt-lifter with low height



Up to 1.500 kg customer load



Up to 1.300 mm stroke



300 mm minimal Height







Flexible height of the Maintenance lock device

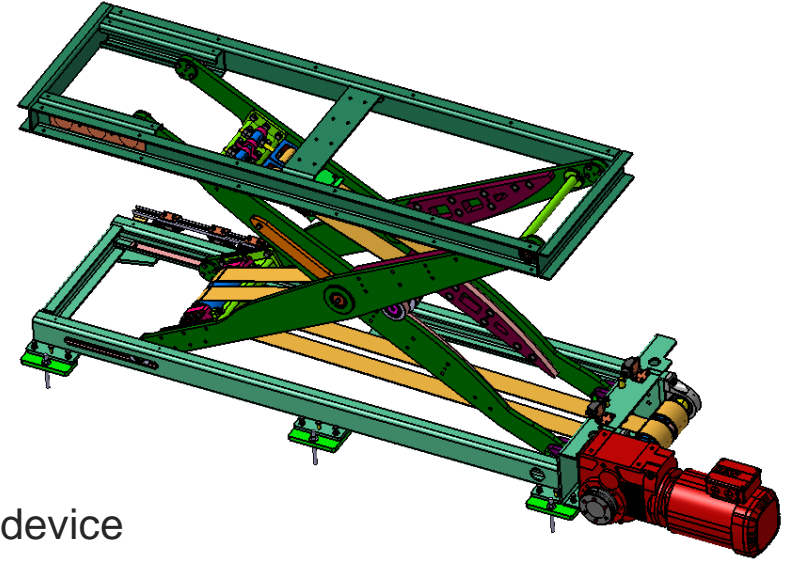

Belt sensors for pretension and defect detection



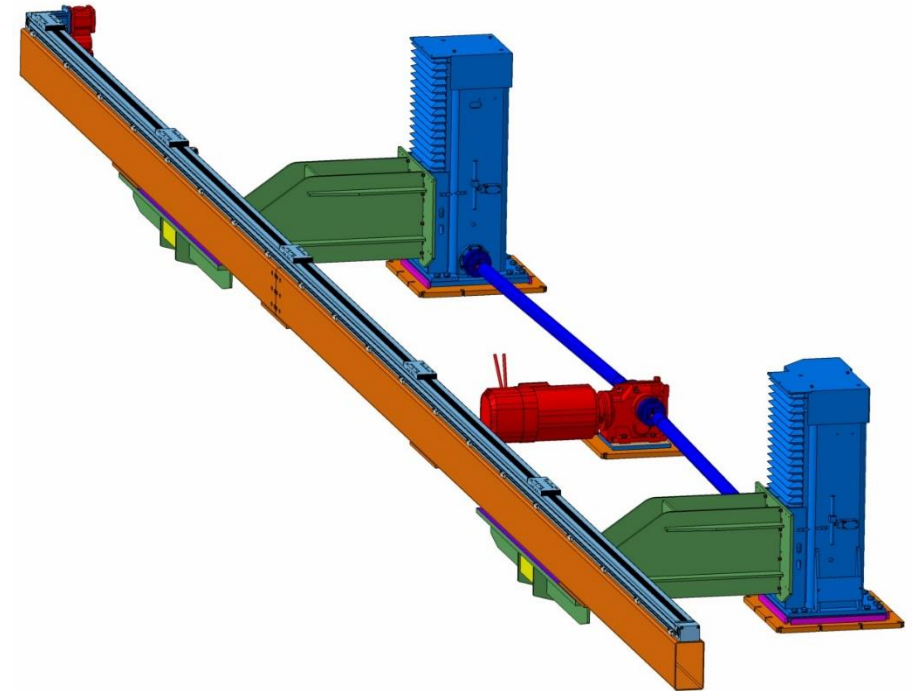

Monorail Lift and Shift

-  Up to 2.000 kg customer load
-  up to 2.000 mm stroke customizable
-  up to 30.000 mm stroke
-  500 mm minimal Height
-  Soft part pick-up with $v = 0$ m/s



Duorail Lift and Shift



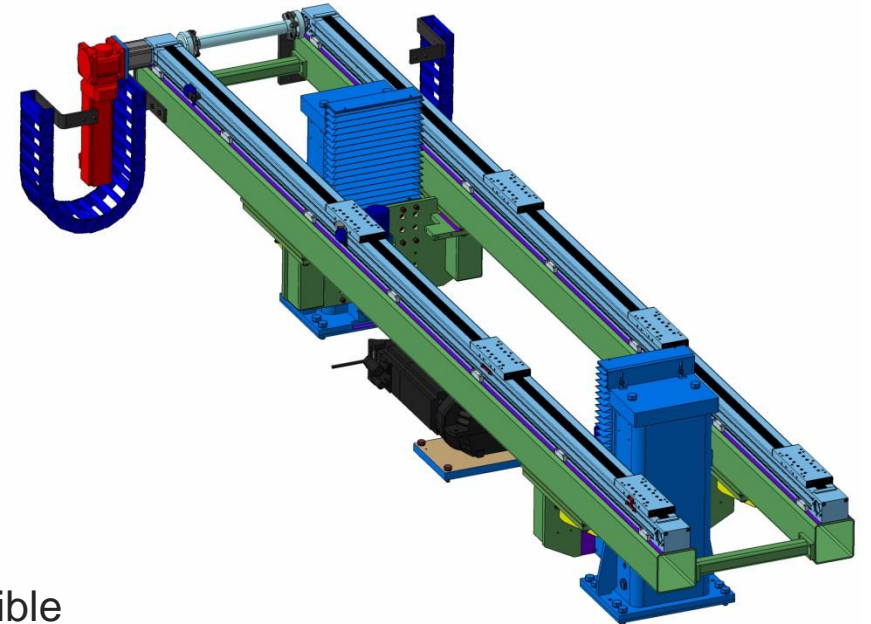

Vertical transporting system for car-body parts

-  Up to 2.000 kg customer load
-  Up to 2.000 mm stroke customizable
-  up to 30.000 mm stroke
-  500 mm minimal Height
-  Soft part pick-up with $v= 0$ m/s
-  Transportation of very large parts possible
-  +/- 0,02 mm vertical Repeatability



Fixed Roller bed at production level

Fixed Roller bed for horizontal motions transportation at production levels

-  Up to 3000 kg customer load
-  Transport height customizable
-  Up to 10.000 mm stroke
-  Forward and Backward motion possible
-  Horizontal Transport without vertical motion

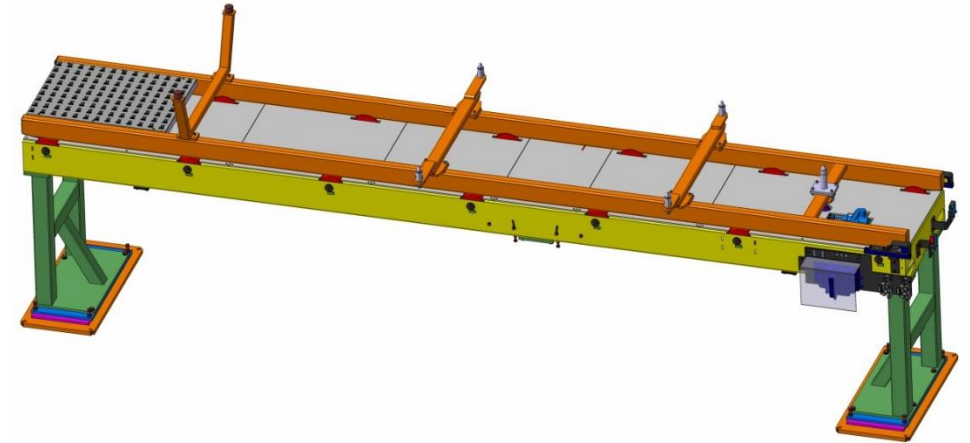

Fixed Roller bed at transportation level

Fixed Roller bed for horizontal motions transportation at upper levels



Up to 3.000 kg customer load



Transport height customizable



Up to 10.000 mm stroke



Forward and Backward motion possible





Easy layout for the upper transportation level

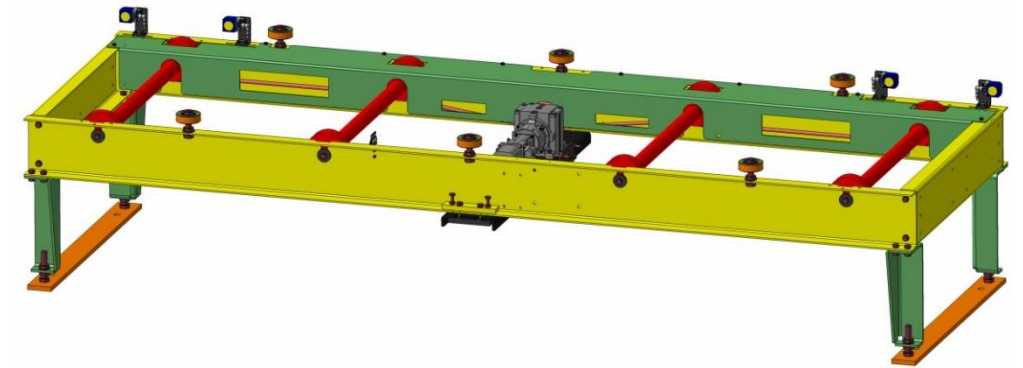

Horizontal Transport without vertical motion



To ensure a safe transportation beyond the allowed gap spacing between stations

-  With or without Motor
-  Movable or fixed (for 7th Axis)
-  Transport height customizable

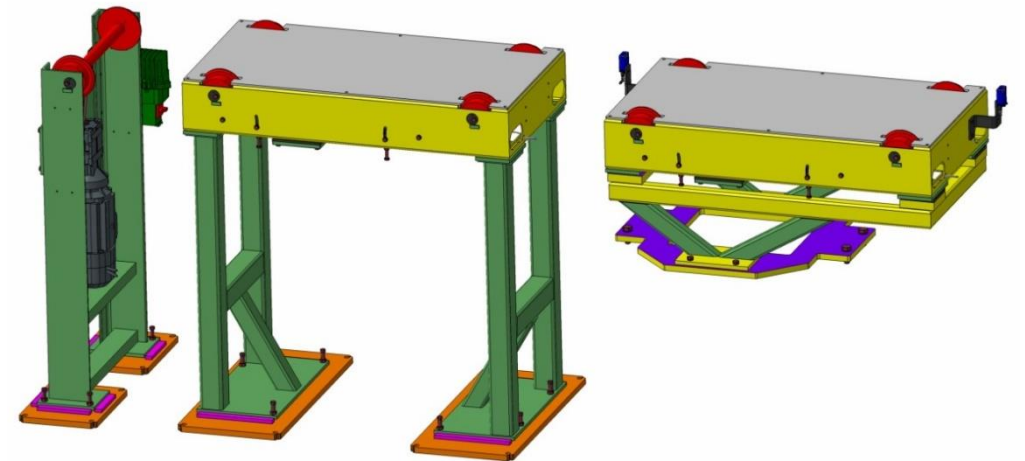

Cross Transport Car

For the connection between Production lines



Up to 3.000 kg customer load



Up to 30.000 mm stroke



600 mm minimal Height





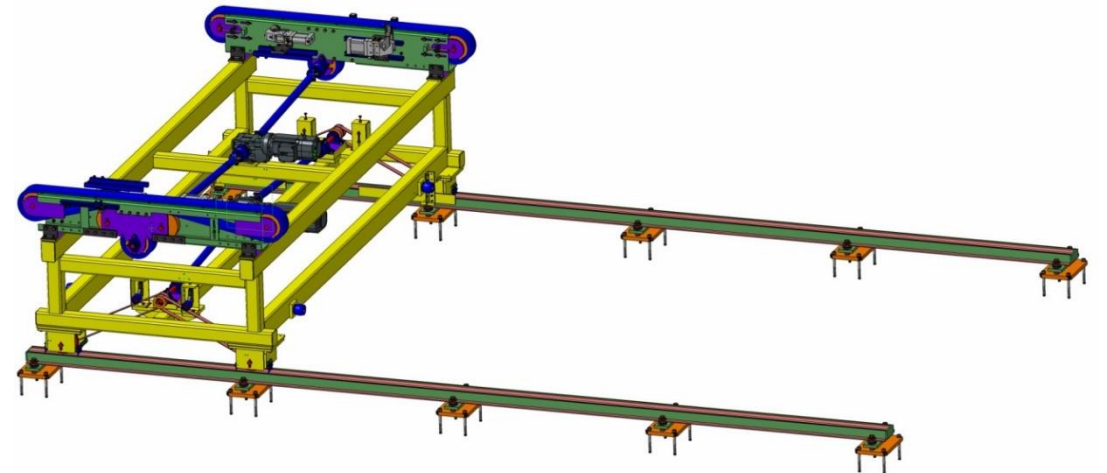

Compact design



Seventh Axis



Linear carrier for up to two Robots

-  Up to 4.000 kg customer load
-  Length up to 30.000 mm
-  Integration of various
Robot types and models
-  Repeatability +/- 0,02 mm
-  Integrated lubrication system



Seventh Axis with Turning Station





Linear carrier for up to two Robots

-  Up to 4.000 kg customer load
-  Length up to 30.000 mm
-  Up to 180° customizable output
-  Integration of various Robot types and models
-  Repeatability +/- 0,02 mm
-  Integrated lubrication system
-  Added Motion degree to the robot



Turning station

Robust Roller bed-Turntable with up to 360° Output angle

-  Up to 3.000 kg customer load
-  Up to 8.000 mm stroke
-  Indexing up to 360°
-  500 mm minimal Height
-  Connects Production lines

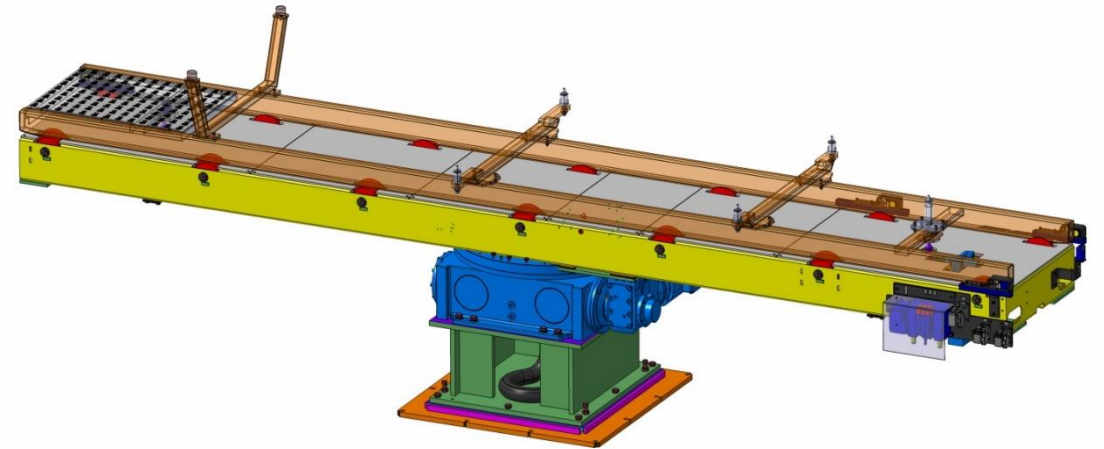

Turning station

Robust Roller bed-Turntable with up to 360° Output angle



Up to 3.000kg customer load



Length up to 8.000 mm



Indexing up to 360°



Tough design with guides



500 mm minimal Height



flexible Speed

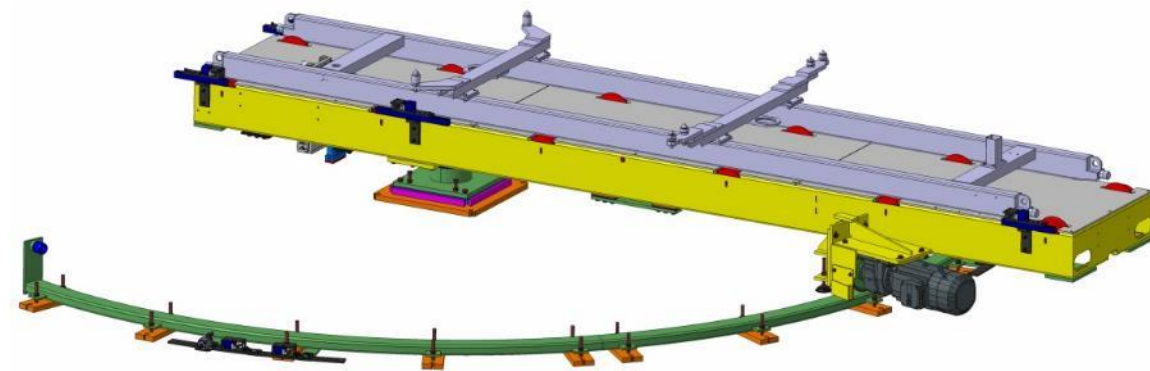

Single lifter

Lift unit with / without cross transfer



customer load up to 3.000 kg



Up to 2.800 mm stroke



Compact design





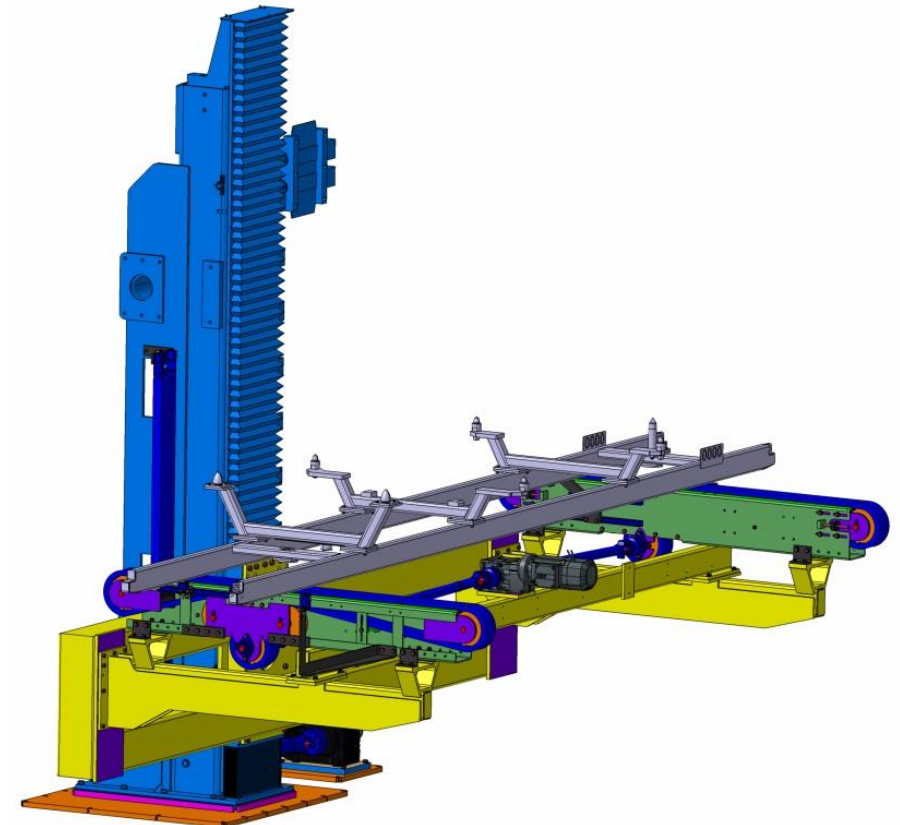

Integrated lubrication system



Lift and turn unit

Lifting unit with turning trunnion

-  Up to 3.000 kg customer load
-  Up to 2.800 mm stroke
-  Indexing up to 360°
-  Allows the reach of complex parts or process on a car body.
-  Integrated lubrication system

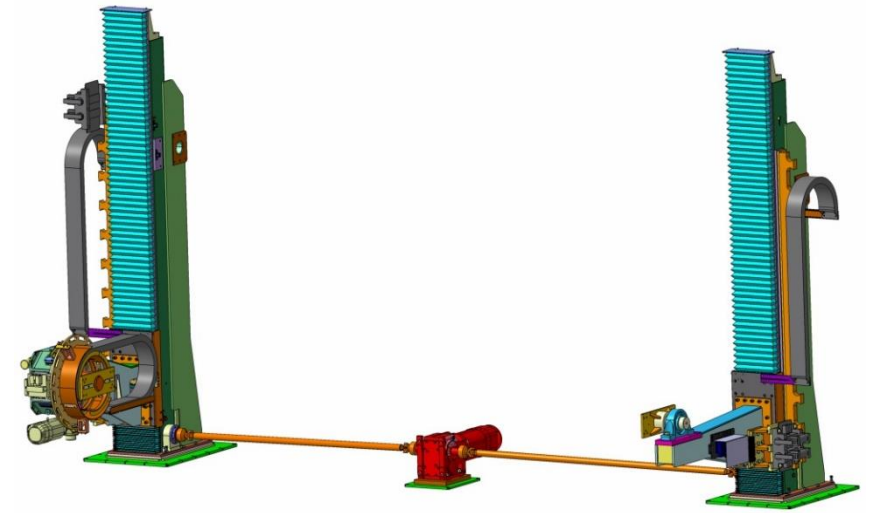

Lift units for car body transportation between production level



Up to 3.000 kg customer load



Up to 20.000 mm stroke



Compact design



Energy optimized (Compensation system)



Second motor as alternative drive



Stroke precision +/- 1mm

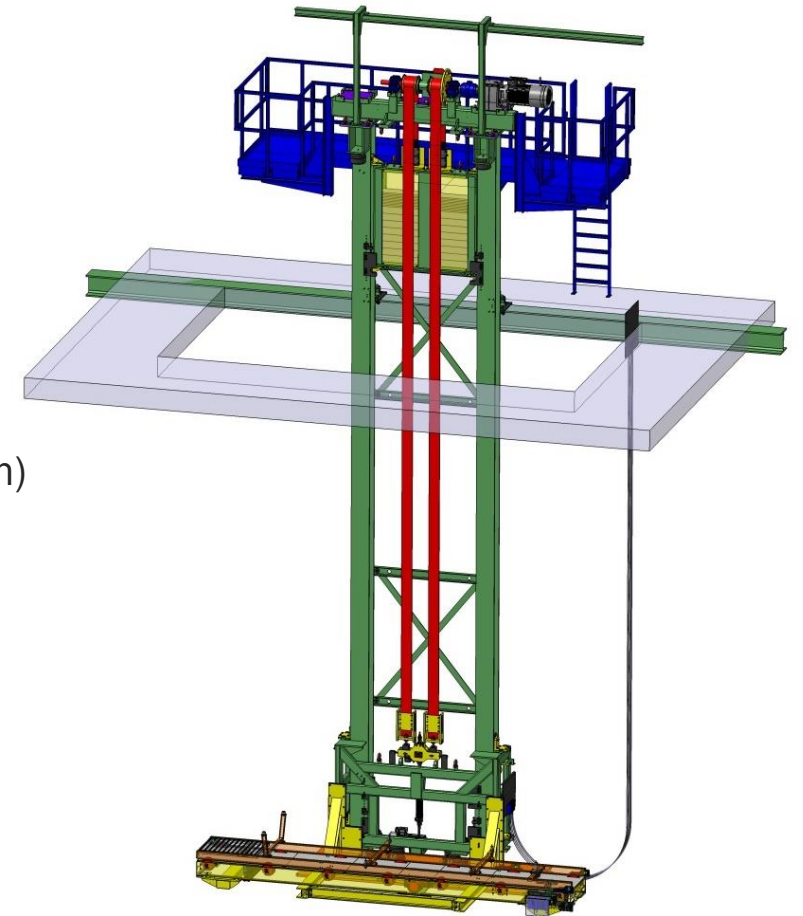

Cross-Transfer

Car body Buffer and transportation system crossways to the production line



Up to 3.000 kg customer load



500 mm minimal Height



Separation between production lines



Multiple Car body Buffer

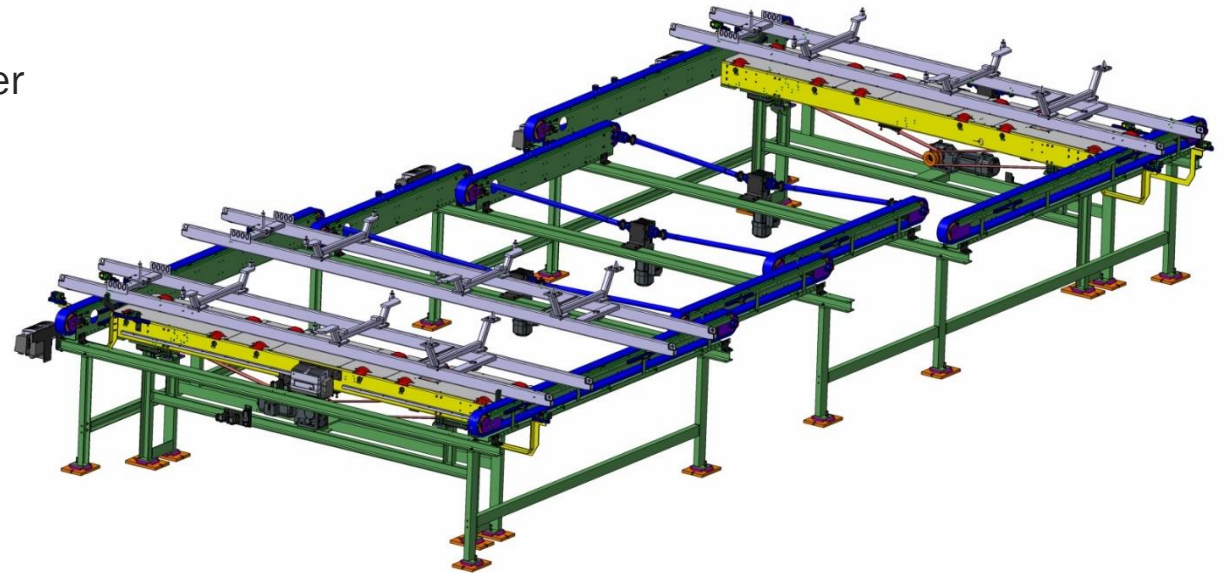



Lift and shift unit

For transport multiple components synchronously
from station to station without jerks or impact

 Up to 500 kg Customer Load per Station

 Up to 1.200 mm vertical stroke

 Up to 8.000 mm horizontal stroke

 800 mm minimal height

 Up to 15 Stations

 Soft part pick-up with $v = 0$ m/s

 Clever compensation system

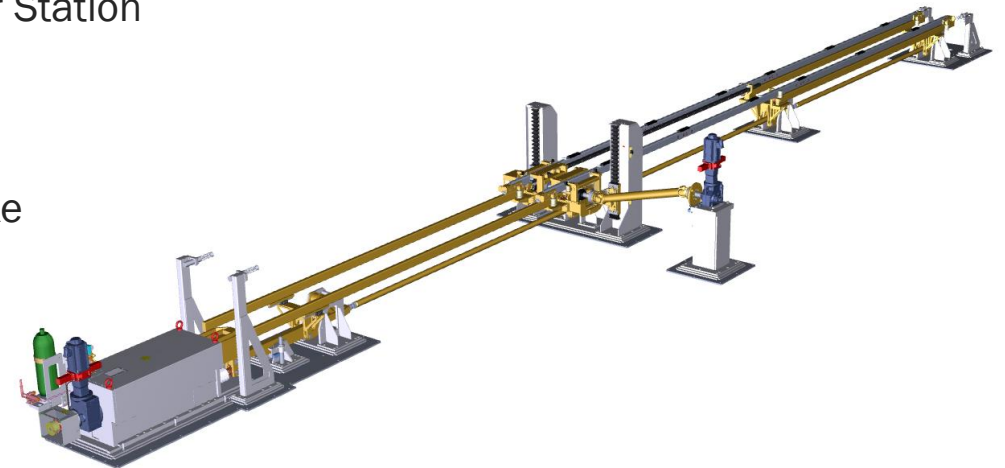

Buffer Ring

Compact Buffer-system in two levels



Up to 2.000 kg customer load



Up to 2.800 mm vertical stroke



Modular, tough design



Customable as 2nd, 6th, 8th or more Buffer ring



Compactness due 2nd level



Specific solution possible

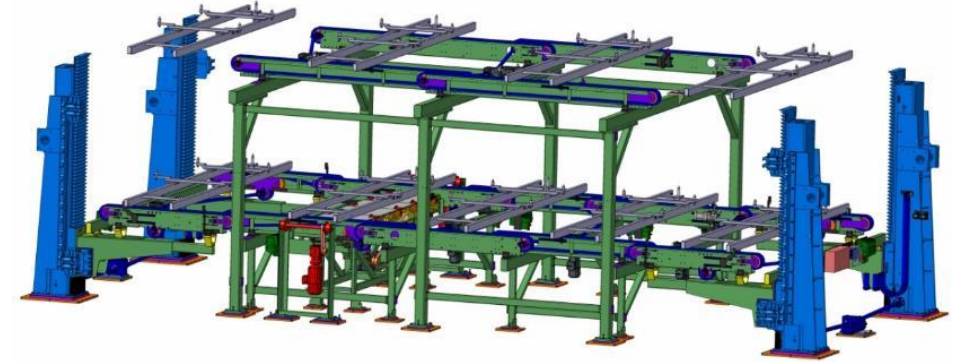

Thank you for your
attention

Contact:

EXPERT-TÜNKERS GmbH
Seehofstr. 5658
64653 Lorsch
Germany

Tel: +49 (0) 6251 / 592-0

Fax: +49 (0) 6251 / 592-100

E-Mail sales@experttuenkers.de

Internet www.experttuenkers.de